

SINGLE REAR WHEEL SHORT BED: 37"-42" CAB TO AXLE

AREA MEASURED	MAKE	WIDTH	HEIGHT	DEPTH
FRONT BOXES	FORD	13½"	32¼"	13"
FRONT BOXES	CHEVY	15½"	32¼"	13"
FRONT BOXES	DODGE	10¾"	32¼"	13"
DRIVER SIDE- WHEEL WELL	-	25"	10⅞"	13"
PASSENGER SIDE- WHEEL WELL	-	36⅝"	10⅞"	13"
REAR BOXES	-	20⅞"	32¼"	13"

* FRONT BOX, CARGO AREA, AND TOTAL BODY SIZES VARY FROM FORD/CHEVY/DODGE.

HPI BODY

AREA MEASURED	MAKE	WIDTH	HEIGHT	DEPTH
CARGO AREA	FORD	50¼"	17⅞"	83⅜"
CARGO AREA	CHEVY	50¼"	17⅞"	85½"
CARGO AREA	DODGE	50¼"	17⅞"	80⅞"
TAILGATE	-	60¾"	13"	3"
TOTAL BODY	FORD	83⅜"	36"	80"
TOTAL BODY	CHEVY	85½"	36"	80"
TOTAL BODY	DODGE	80¼"	36"	80"

* All measurements of compartment boxes are from perspective of box opening and are based on actual opening size.

* All other measurements are from perspective of facing the tailgate.

* Driver side wheel well box has concealed fuel fill, affecting the size of the box opening on that side.

* All measurements are: (W) Width x (H) Height x (D) Depth

HPI BODY

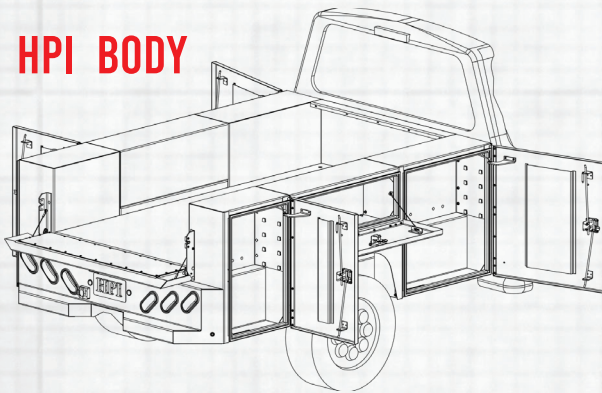

TRANSVERSE BODY

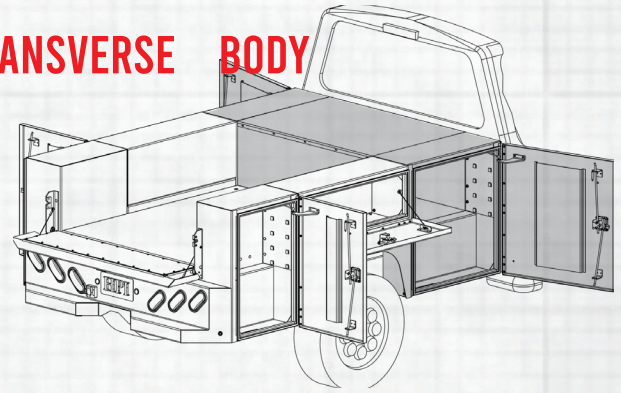

SINGLE REAR WHEEL: 56" CAB TO AXLE HPI BODY

AREA MEASURED	WIDTH	HEIGHT	DEPTH
DRIVER & PASSENGER FRONT BOX	30⅞"	32¼"	13"
DRIVER SIDE WHEEL WELL BOX	25"	10⅞"	13"
PASSENGER WHEEL WELL BOX	36⅝"	10⅞"	13"
REAR BOXES	20⅞"	32¼"	13"
TAILGATE	60¾"	13"	3"
CARGO AREA	50¼"	17⅞"	100"
TOTAL BODY	100"	36"	80"

SINGLE REAR WHEEL: 56" CAB TO AXLE TRANSVERSE BODY

AREA MEASURED	WIDTH	HEIGHT	DEPTH
DRIVER & PASSENGER FRONT BOX	30⅞"	32¼"	80"
DRIVER SIDE WHEEL WELL BOX	25"	10⅞"	13"
PASSENGER WHEEL WELL BOX	36¾"	10⅞"	13"
REAR BOXES	20⅞"	32¼"	13"
TAILGATE	60¾"	13"	3"
CARGO AREA	50¼"	17⅞"	100"
TOTAL BODY	100"	36"	80"

DUAL REAR WHEEL: 56" CAB TO AXLE**HPI BODY**

AREA MEASURED	WIDTH	HEIGHT	DEPTH
FRONT BOX	30 ¹ / ₈ "	32 ¹ / ₄ "	20 ⁷ / ₈ "
DRIVER SIDE WHEEL WELL BOX	25 ¹ / ₈ "	10 ⁷ / ₈ "	20 ⁷ / ₈ "
PASSENGER WHEEL WELL BOX	36 ⁵ / ₈ "	10 ⁷ / ₈ "	20 ⁷ / ₈ "
REAR BOXES	20 ¹ / ₈ "	32 ¹ / ₄ "	20 ⁷ / ₈ "
TAILGATE	60 ³ / ₄ "	13"	3"
CARGO AREA	50 ¹ / ₄ "	17 ³ / ₈ "	100"
TOTAL BODY	100"	36"	96"

DUAL REAR WHEEL: 56" CAB TO AXLE**TRANSVERSE BODY**

AREA MEASURED	WIDTH	HEIGHT	DEPTH
FRONT BOX	30 ¹ / ₈ "	32 ¹ / ₄ "	96"
DRIVER SIDE WHEEL WELL BOX	25 ¹ / ₈ "	10 ⁷ / ₈ "	20 ⁷ / ₈ "
PASSENGER WHEEL WELL BOX	36 ⁵ / ₈ "	10 ⁷ / ₈ "	20 ⁷ / ₈ "
REAR BOXES	20 ¹ / ₈ "	32 ¹ / ₄ "	20 ⁷ / ₈ "
TAILGATE	60 ³ / ₄ "	13"	3"
CARGO AREA	50 ¹ / ₄ "	17 ³ / ₈ "	65 ¹ / ₄ "
BODY	100"	36"	96"

SINGLE REAR WHEEL: 60" CAB TO AXLE**HPI BODY**

AREA MEASURED	WIDTH	HEIGHT	DEPTH
FRONT BOX	33 ¹ / ₂ "	34 ¹ / ₄ "	13"
DRIVER SIDE WHEEL WELL BOX	25 ¹ / ₈ "	13 ⁷ / ₈ "	13"
PASSENGER WHEEL WELL BOX	36 ⁵ / ₈ "	13 ⁷ / ₈ "	13"
REAR BOXES	26 ⁵ / ₈ "	34 ¹ / ₄ "	13"
TAILGATE	60 ³ / ₄ "	13"	3"
CARGO AREA	50 ¹ / ₄ "	18 ⁷ / ₈ "	110"
TOTAL BODY	110"	38"	80"

SINGLE REAR WHEEL: 60" CAB TO AXLE**TRANSVERSE BODY**

AREA MEASURED	WIDTH	HEIGHT	DEPTH
FRONT BOX	33 ¹ / ₂ "	34 ¹ / ₄ "	80"
DRIVER SIDE WHEEL WELL BOX	25 ¹ / ₈ "	13 ⁷ / ₈ "	13"
PASSENGER WHEEL WELL BOX	36 ⁵ / ₈ "	13 ⁷ / ₈ "	13"
REAR BOXES	26 ⁵ / ₈ "	34 ¹ / ₄ "	13"
TAILGATE	60 ³ / ₄ "	13"	3"
CARGO AREA	50 ¹ / ₄ "	18 ⁷ / ₈ "	71 ³ / ₄ "
TOTAL BODY	110"	38"	80"

DUAL REAR WHEEL: 60" CAB TO AXLE**HPI BODY**

AREA MEASURED	WIDTH	HEIGHT	DEPTH
FRONT BOX	33 ¹ / ₂ "	34 ¹ / ₄ "	20 ⁷ / ₈ "
DRIVER SIDE WHEEL WELL BOX	25 ¹ / ₈ "	13 ⁷ / ₈ "	20 ⁷ / ₈ "
PASSENGER WHEEL WELL BOX	36 ⁵ / ₈ "	13 ⁷ / ₈ "	20 ⁷ / ₈ "
REAR BOXES	26 ⁵ / ₈ "	34 ¹ / ₄ "	20 ⁷ / ₈ "
TAILGATE	60 ³ / ₄ "	13"	3"
CARGO AREA	50 ¹ / ₄ "	18 ⁷ / ₈ "	110"
TOTAL BODY	110"	38"	96"

DUAL REAR WHEEL: 60" CAB TO AXLE**TRANSVERSE BODY**

AREA MEASURED	WIDTH	HEIGHT	DEPTH
FRONT BOX	33 ¹ / ₂ "	34 ¹ / ₄ "	96"
DRIVER SIDE WHEEL WELL BOX	25 ¹ / ₈ "	13 ⁷ / ₈ "	20 ⁷ / ₈ "
PASSENGER WHEEL WELL BOX	36 ⁵ / ₈ "	13 ⁷ / ₈ "	20 ⁷ / ₈ "
REAR BOXES	26 ⁵ / ₈ "	34 ¹ / ₄ "	20 ⁷ / ₈ "
TAILGATE	60 ³ / ₄ "	13"	3"
CARGO AREA	50 ¹ / ₄ "	18 ⁷ / ₈ "	71 ³ / ₄ "
TOTAL BODY	110"	38"	96"