

OPTIONS	YES	NO	LOCATION	QTY
FRONT DRAWER	X		DS&PS	3
FRONT SHELVES	X		DS&PS	5
REAR FIXED SHELVES	X		DS&PS	4
REAR DRAWERS	X		DS&PS	2
STANDARD DECK	X		—	—
INTERIOR LIGHTS LED	X		—	2
INSTALL KIT	X		—	—

TRUCK SPECIFICATIONS

2018 DODGE-5500
CHASSIS CAB
 CA= 84"
 FRAME AFT OF AXLE=51.1"
 FRAME WIDTH= 34"
 TIRE SIZE= 37"

OTHER OPTIONAL BOXES
 (SHOWN ON NEXT PAGE)
 31x53.5x12 AL DBL DOOR BOX
 (9002-690)
 23x17x11.5 AL SIDE OPEN BOX
 (9003-605)

SPARE TIRE MOUNT
 WHEEL CHOCK STYLE
 (9055-99-032)

ADJ SHELF TAB BRACKET
 WITH OPTIONAL REMOVABLE SHELVES

12 VOLT LED LIGHT KIT
 BOXES (590-00057)x2

FRONT PS DRAWER SLIDE
 (9059-19-092)

FRONT TIE DOWN MOUNTS
 (9059-20-006)

1/8" DP DECK
 (9059-04-051)

BACK TIE
 DOWN MOUNTS
 (9059-20-007)

PC LX FI

DS & PS ADJ SHELVES
 (9059-11-045)x2
 DS & PS 2 DRAWER SLIDE
 (9059-19-082)x2

REAR ADJ SHELF
 (9059-11-048)x2

MOUNT KIT
 (550-00012)

HITCH
 (9055-068)

BUMPER
 (9059-06-020)

MATERIAL:		ALUMINUM		PROJECT #:	2734
FINISH:		DP & SMOOTH			
REVISION:	APVL BY:	ENG DATE:			
AB	DAL	07/25/2019			
Ov1					

135" x 48" x 96" SERVICEBODY

HIGHWAY
 PRODUCTS
 1-800-TOOL BOX
 FAX 1-800-465-9545
 800TOOLBOX.COM

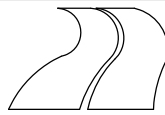

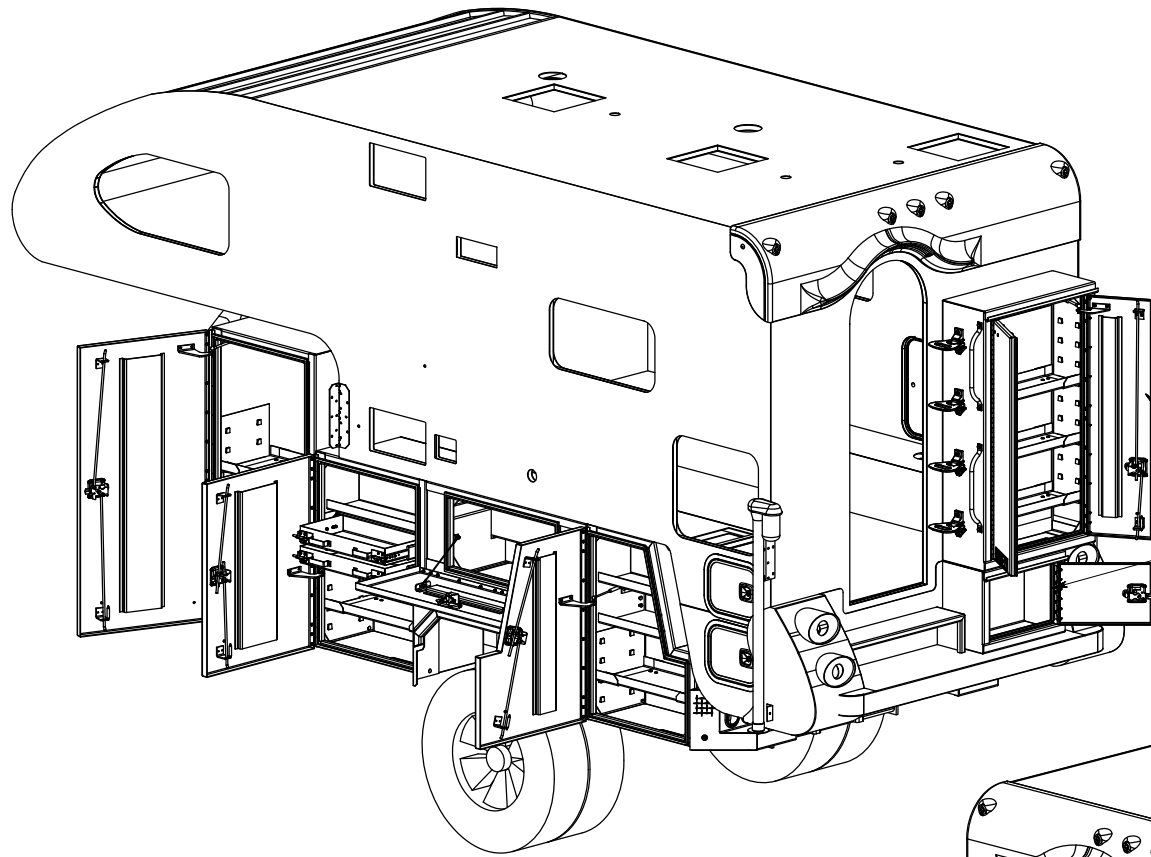

31x53.5x12 AL DBL DOOR BOX
(9002-690)
23x17x11.5 AL SIDE OPEN BOX
(9003-605)

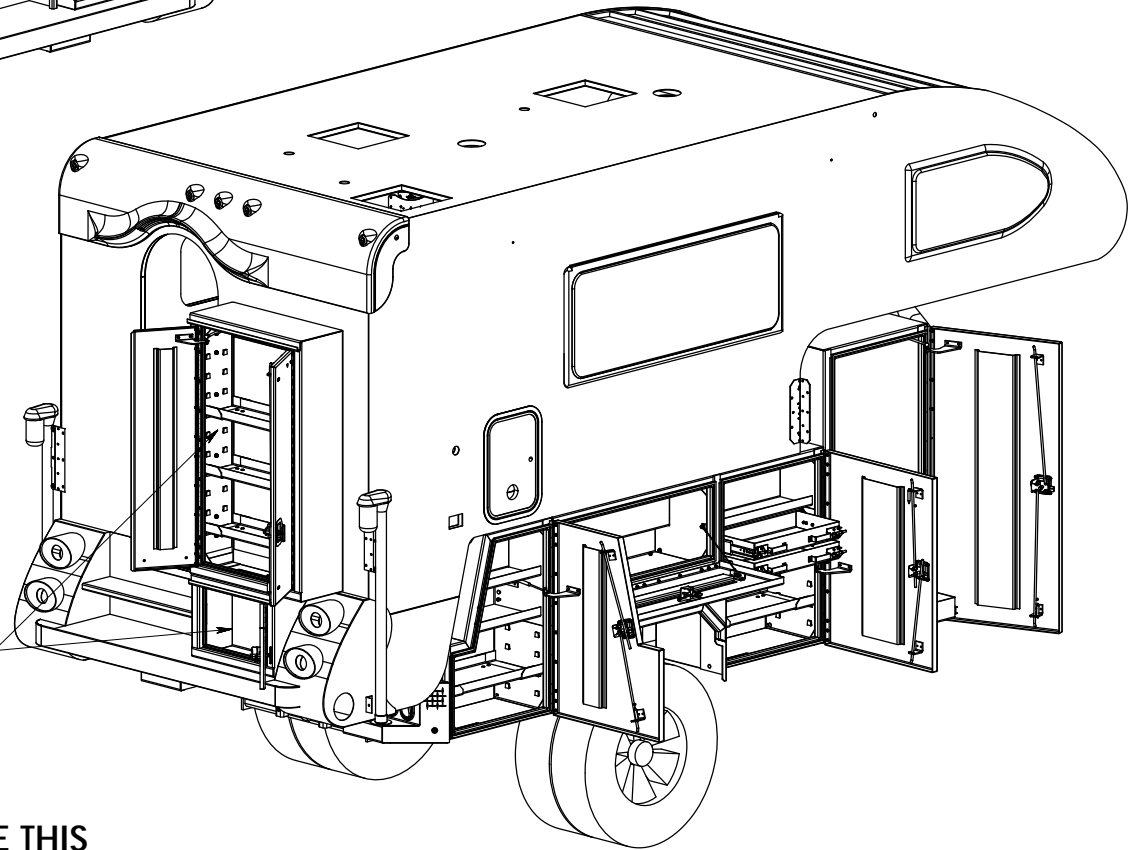

31x53.5x12 AL DBL DOOR BOX
(9002-690)
23x17x11.5 AL SIDE OPEN BOX
(9003-605)

APPROVAL SIGNATURE _____

ESTIMATED LEAD TIME DOES NOT START UNTIL WE RECEIVE THIS
PRINT WITH YOUR APPROVAL SIGNATURE ON IT WITH NO CHANGES

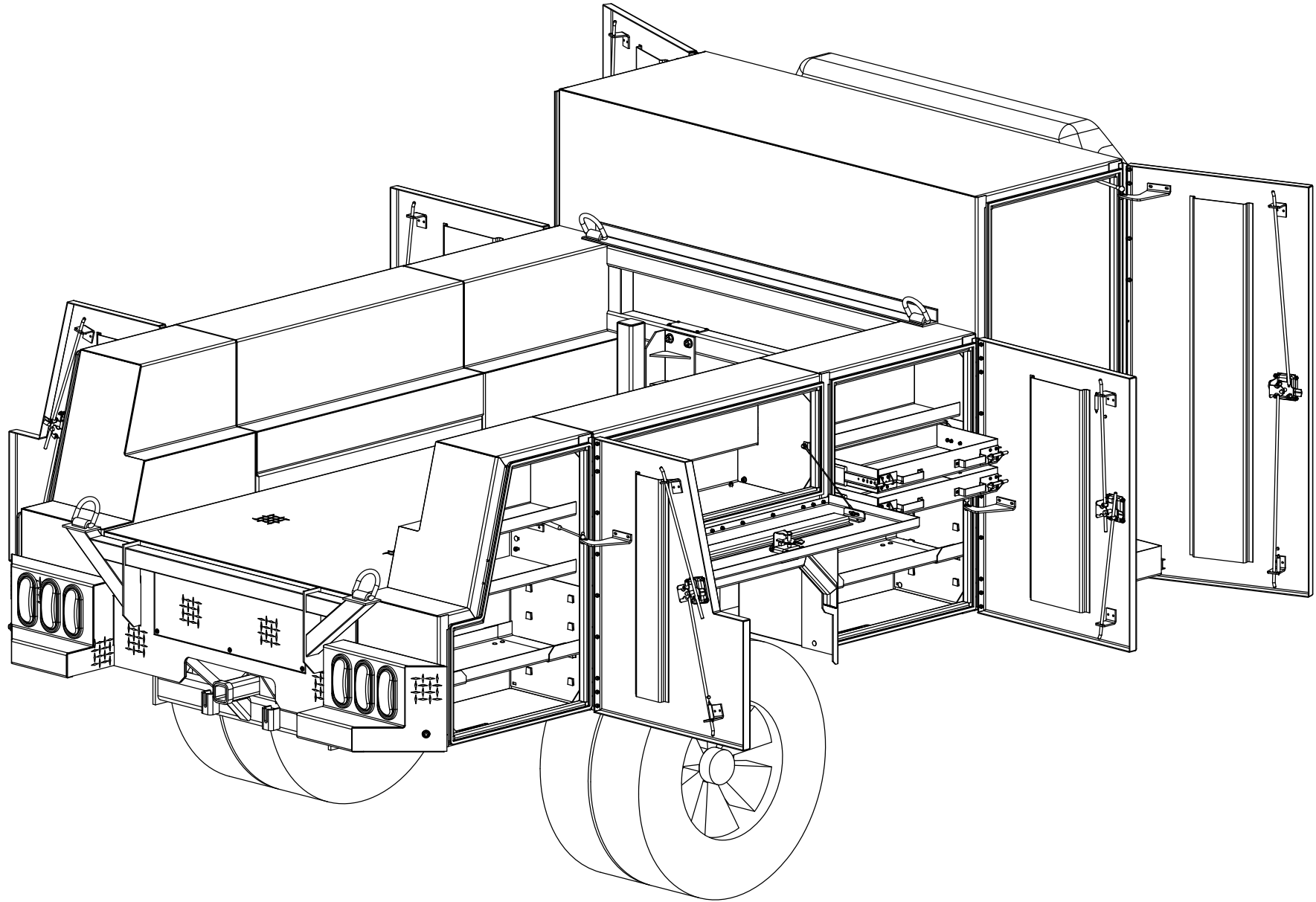

APPROVAL SIGNATURE _____

PS ISOMETRIC VIEW WITH THE DOORS OPEN

ESTIMATED LEAD TIME DOES NOT START UNTIL WE RECEIVE THIS PRINT WITH YOUR APPROVAL SIGNATURE ON IT WITH NO CHANGES

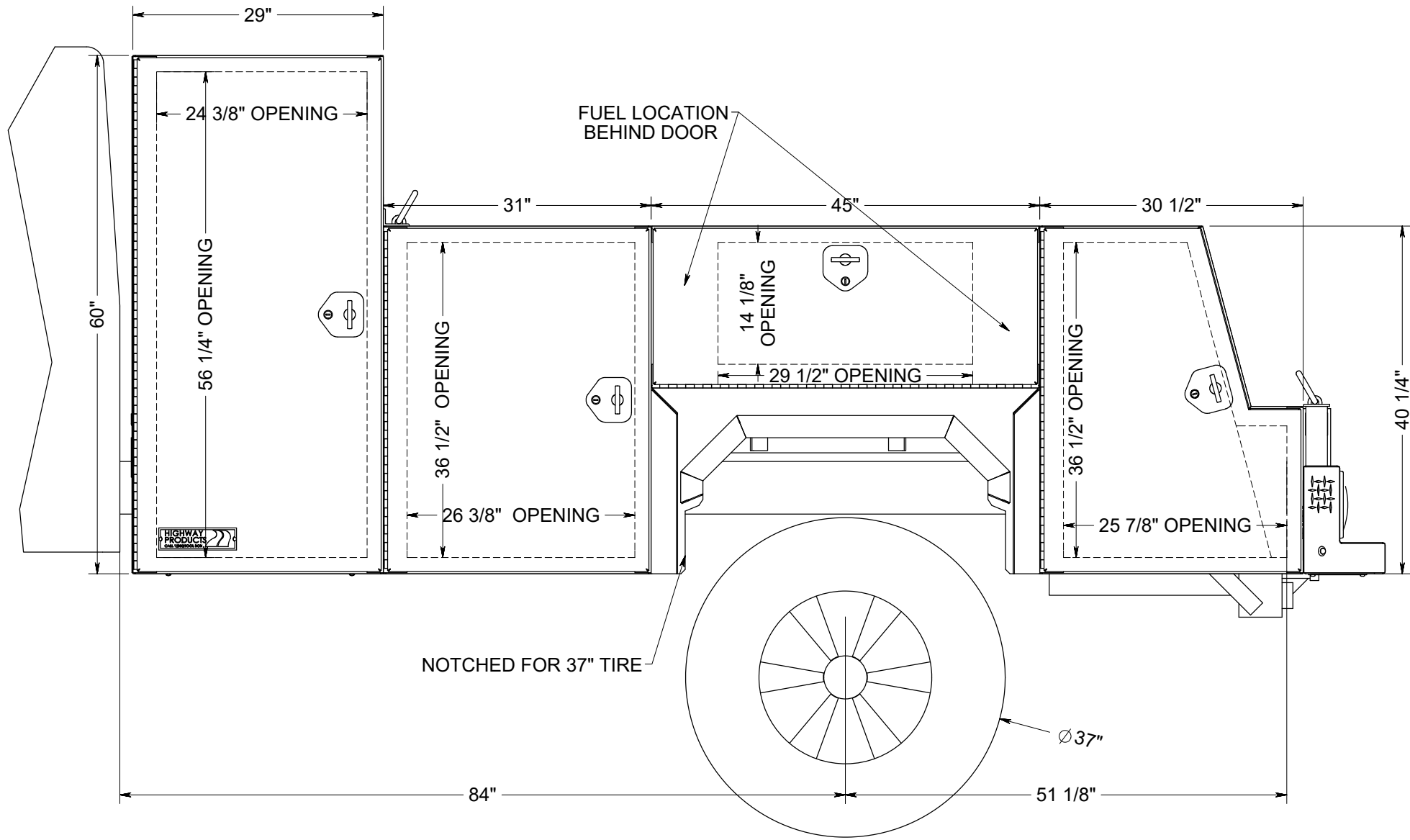

DS VIEW

APPROVAL SIGNATURE _____

ESTIMATED LEAD TIME DOES NOT START UNTIL WE RECEIVE THIS PRINT WITH YOUR APPROVAL SIGNATURE ON IT WITH NO CHANGES

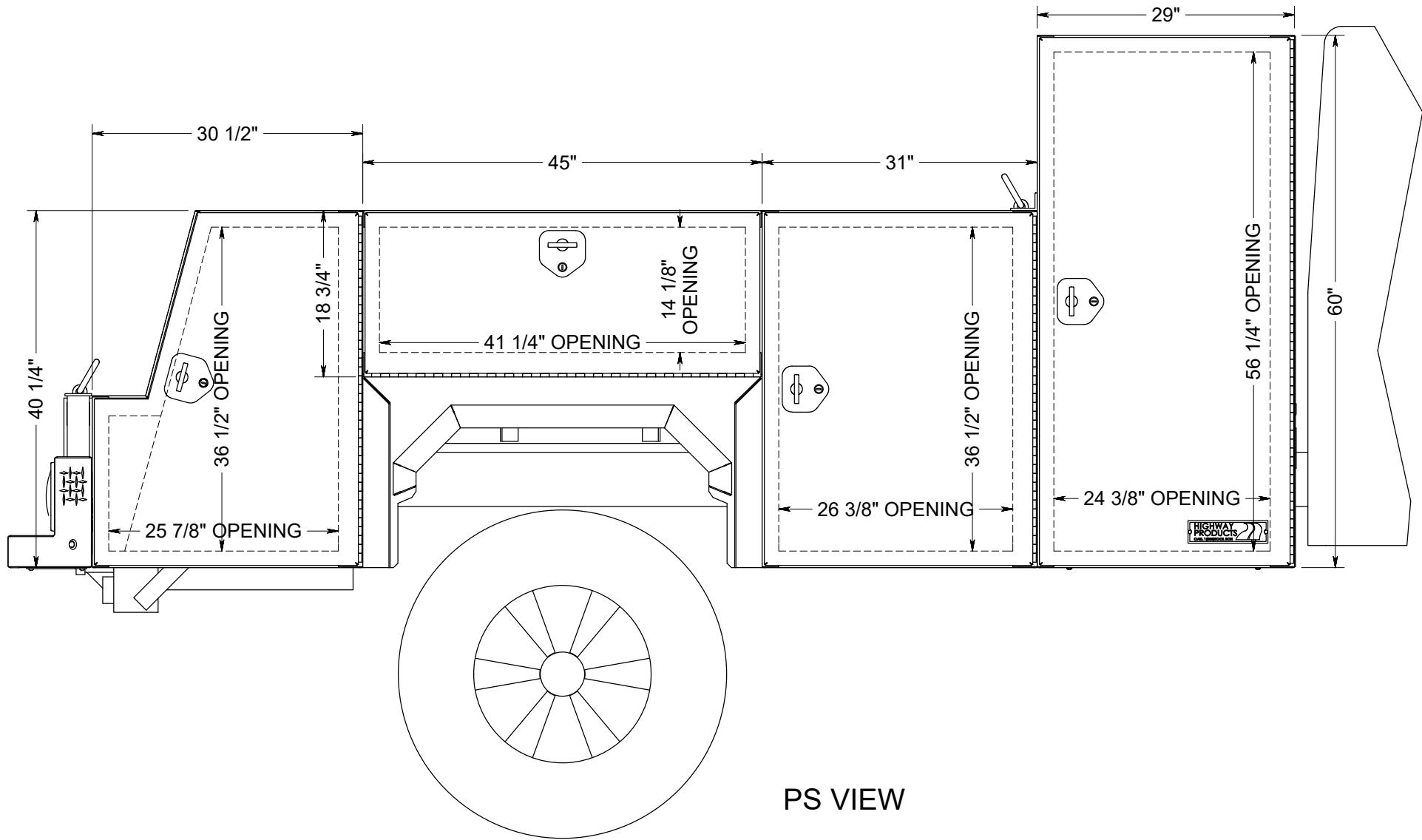

PS VIEW

APPROVAL SIGNATURE _____

ESTIMATED LEAD TIME DOES NOT START UNTIL WE RECEIVE THIS PRINT WITH YOUR APPROVAL SIGNATURE ON IT WITH NO CHANGES

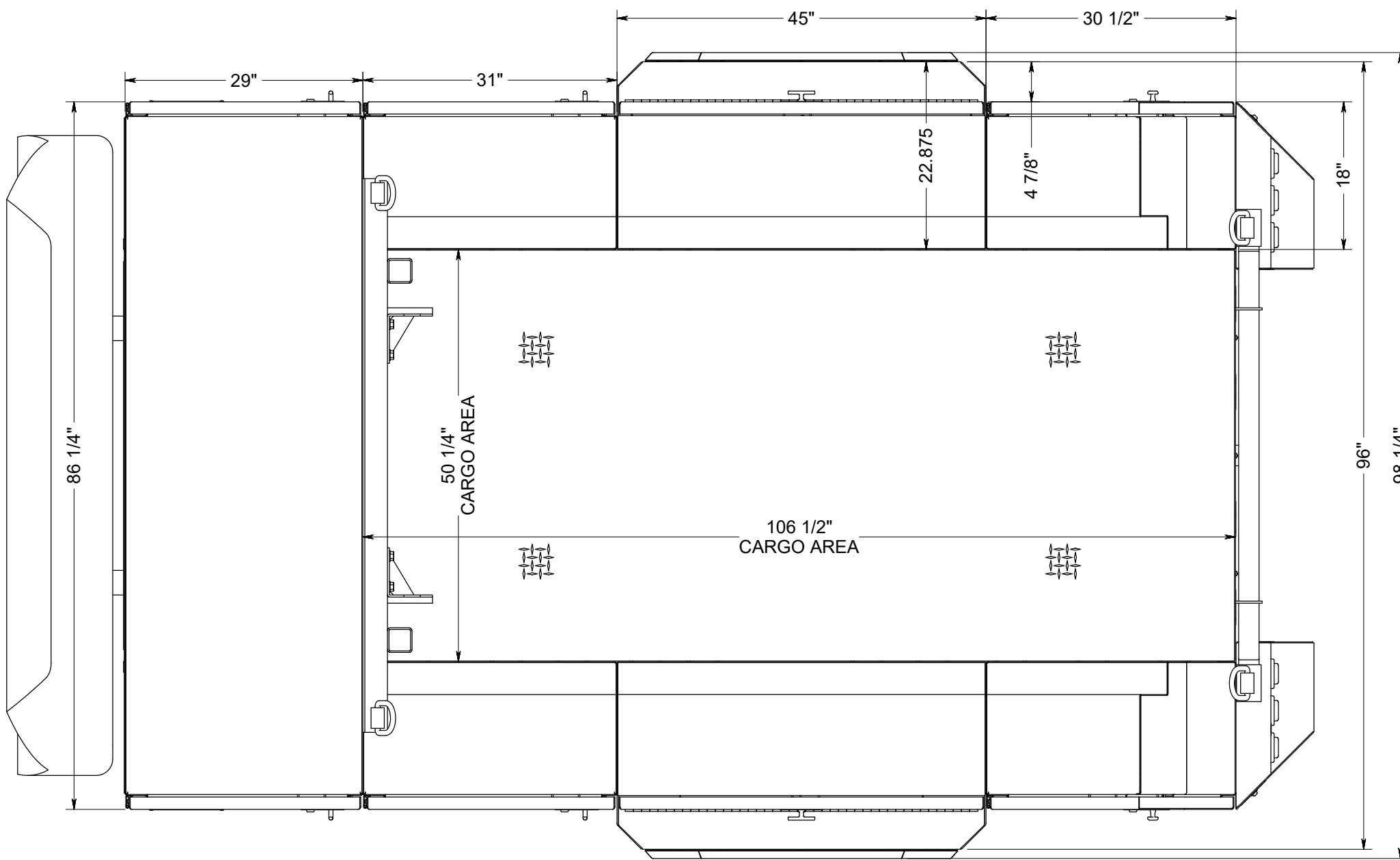

APPROVAL SIGNATURE _____

TOP VIEW

ESTIMATED LEAD TIME DOES NOT START UNTIL WE RECEIVE THIS PRINT WITH YOUR APPROVAL SIGNATURE ON IT WITH NO CHANGES

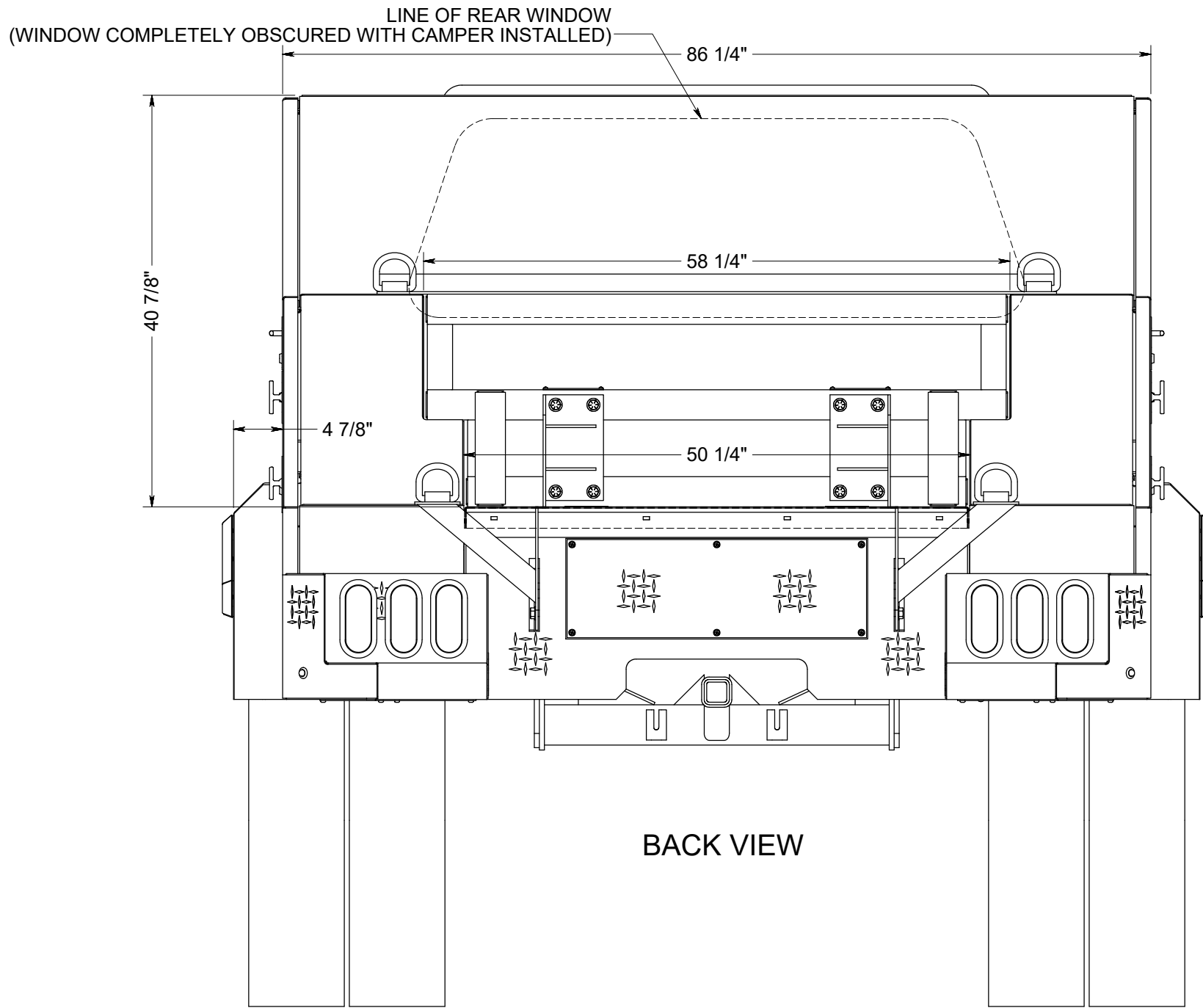

APPROVAL SIGNATURE _____

ESTIMATED LEAD TIME DOES NOT START UNTIL WE RECEIVE THIS PRINT WITH YOUR APPROVAL SIGNATURE ON IT WITH NO CHANGES

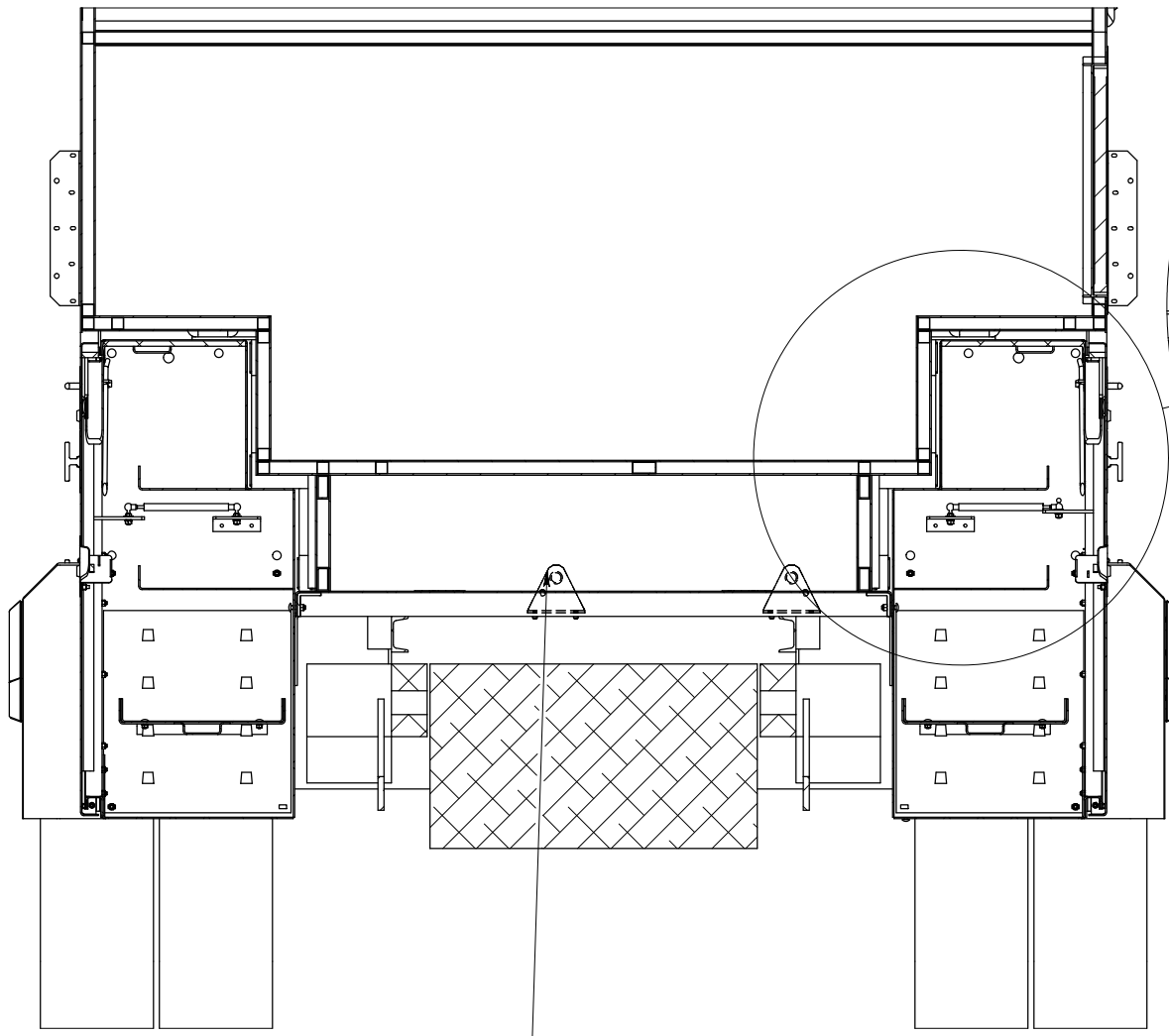

TIRE MOUNT CHOCK ASSEMBLY IN FRONT BOX

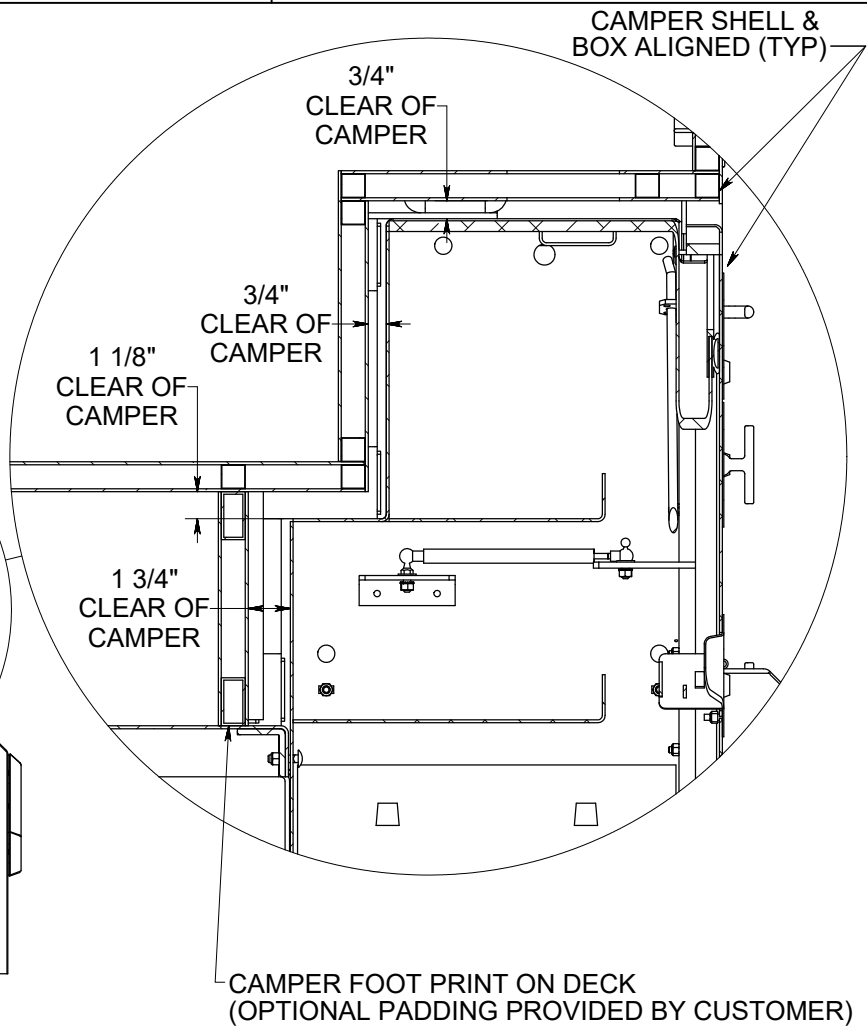

CAMPER SHELL & BOX ALIGNED (TYP)

3/4" CLEAR OF CAMPER

3/4" CLEAR OF CAMPER

1 1/8" CLEAR OF CAMPER

1 3/4" CLEAR OF CAMPER

CAMPER FOOT PRINT ON DECK (OPTIONAL PADDING PROVIDED BY CUSTOMER)

APPROVAL SIGNATURE _____

DETAIL M
SCALE 1 : 8

ESTIMATED LEAD TIME DOES NOT START UNTIL WE RECEIVE THIS PRINT WITH YOUR APPROVAL SIGNATURE ON IT WITH NO CHANGES

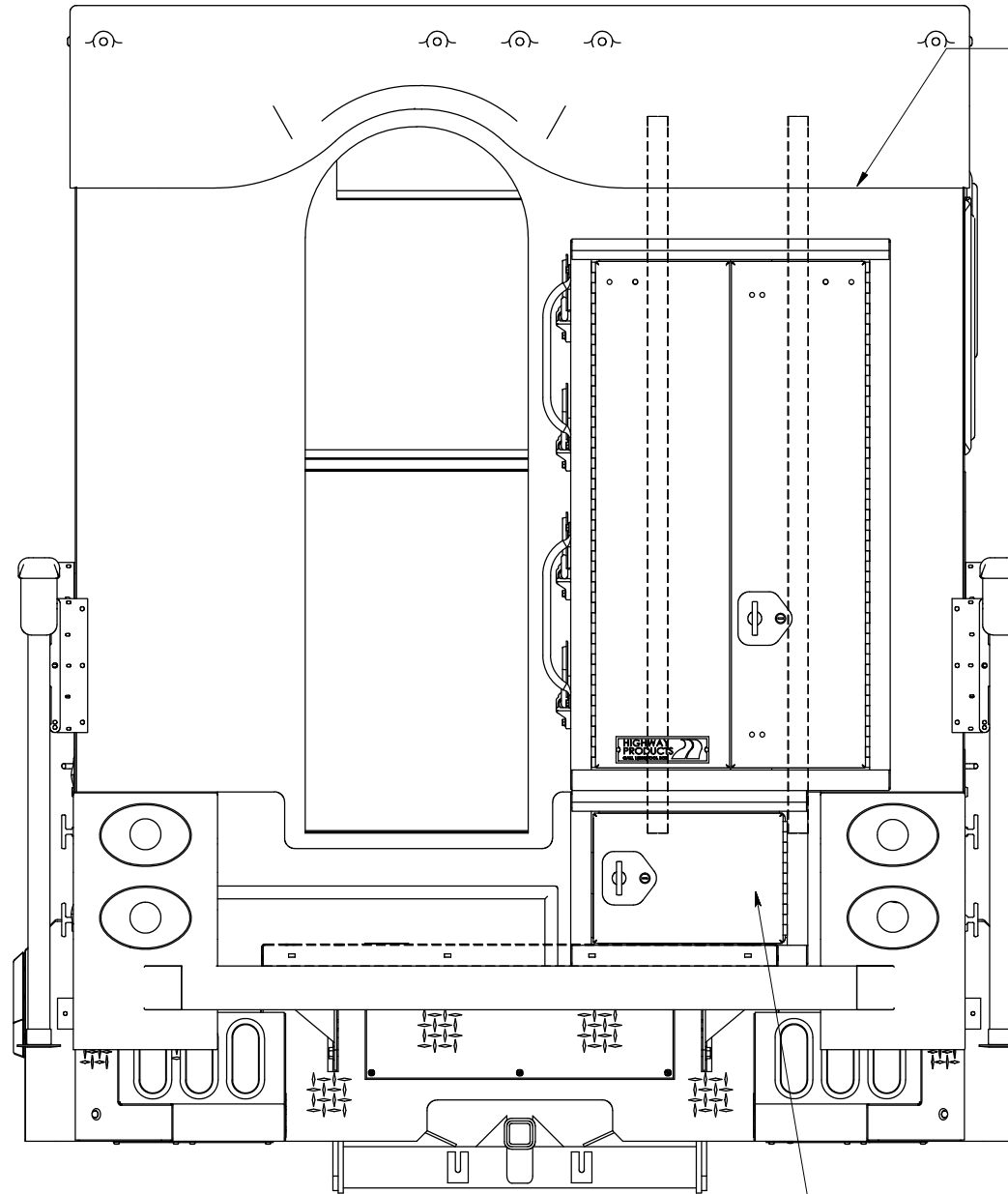

LOCATE AND MOUNT TOP DBL DOOR BOX TO CAMPER'S BACK STUCTURAL MEMBERS WHERE LADDER WAS FASTENED

MOUNT SIDE OPEN BOX TO CAMPER BUMPER

BACK BOX MOUNT VIEW

APPROVAL SIGNATURE _____
ESTIMATED LEAD TIME DOES NOT START UNTIL WE RECEIVE THIS
PRINT WITH YOUR APPROVAL SIGNATURE ON IT WITH NO CHANGES

REMOVABLE SHELVES

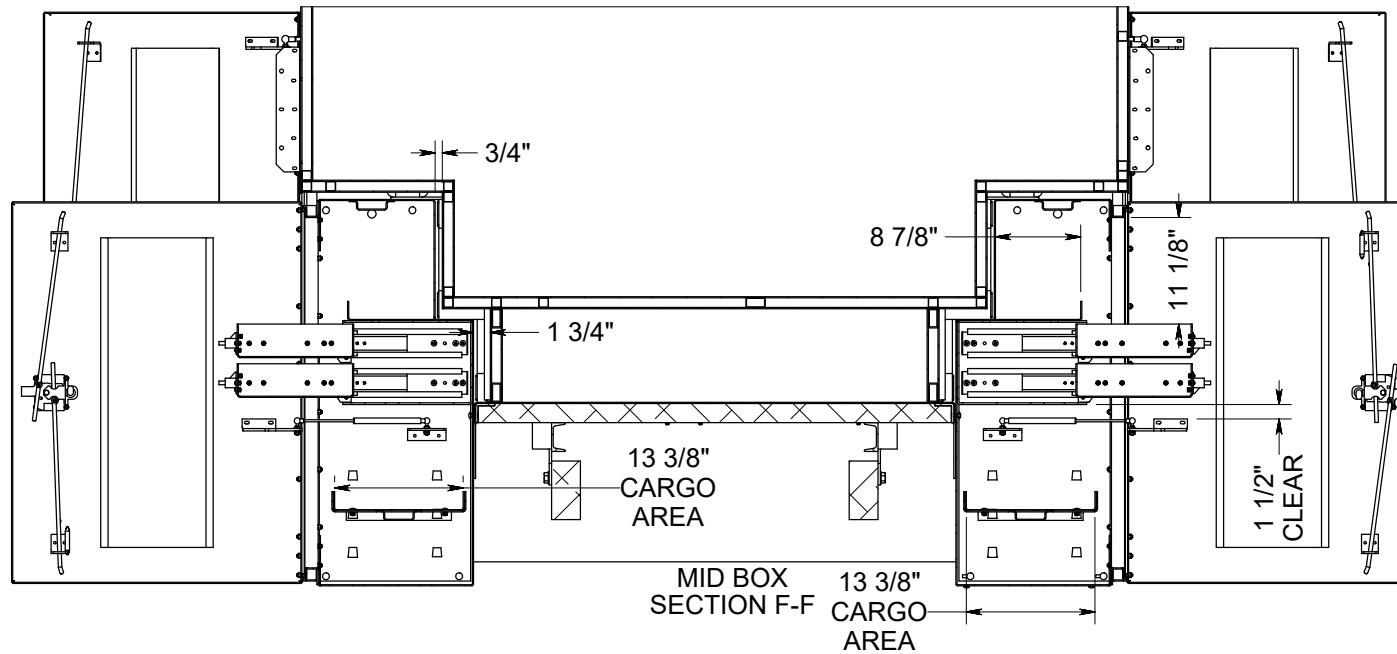
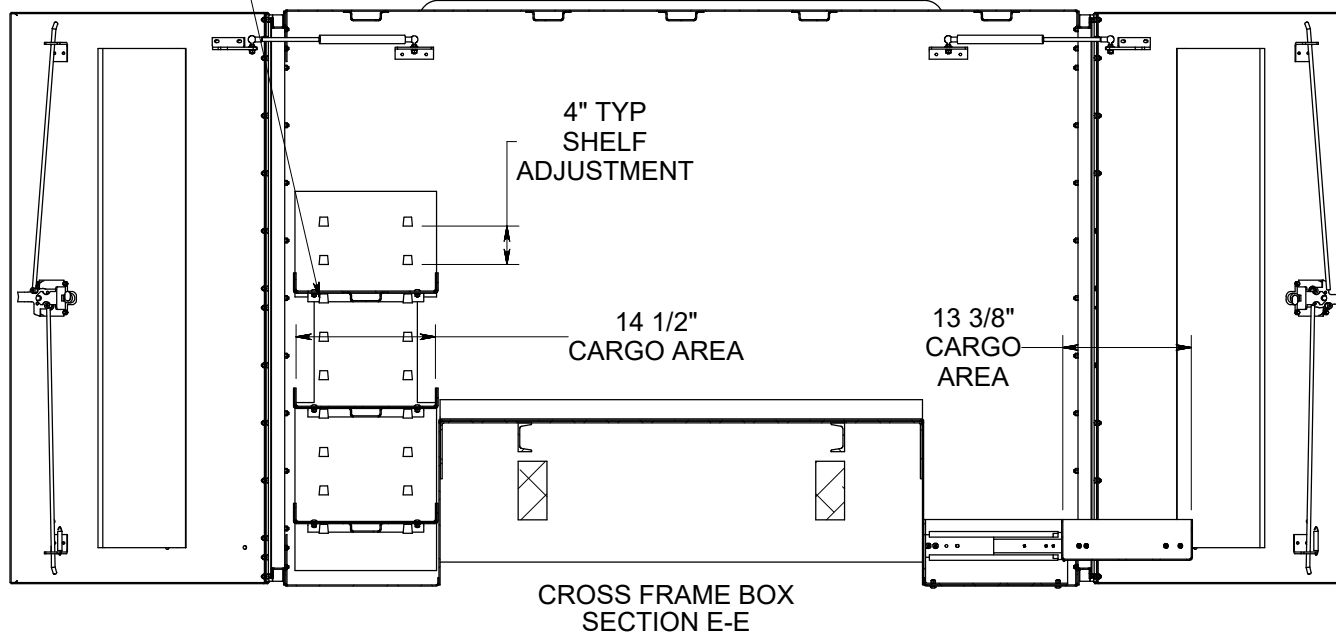

APPROVAL SIGNATURE _____

ESTIMATED LEAD TIME DOES NOT START UNTIL WE RECEIVE THIS PRINT WITH YOUR APPROVAL SIGNATURE ON IT WITH NO CHANGES

Screw SS .25-20x.75 Pan Head Phillips
Nutsert 1/4-20 Large Flange

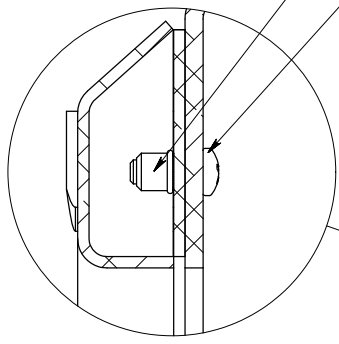

DETAIL J
FENDER FLARE PROFILE
SCALE 1 : 2

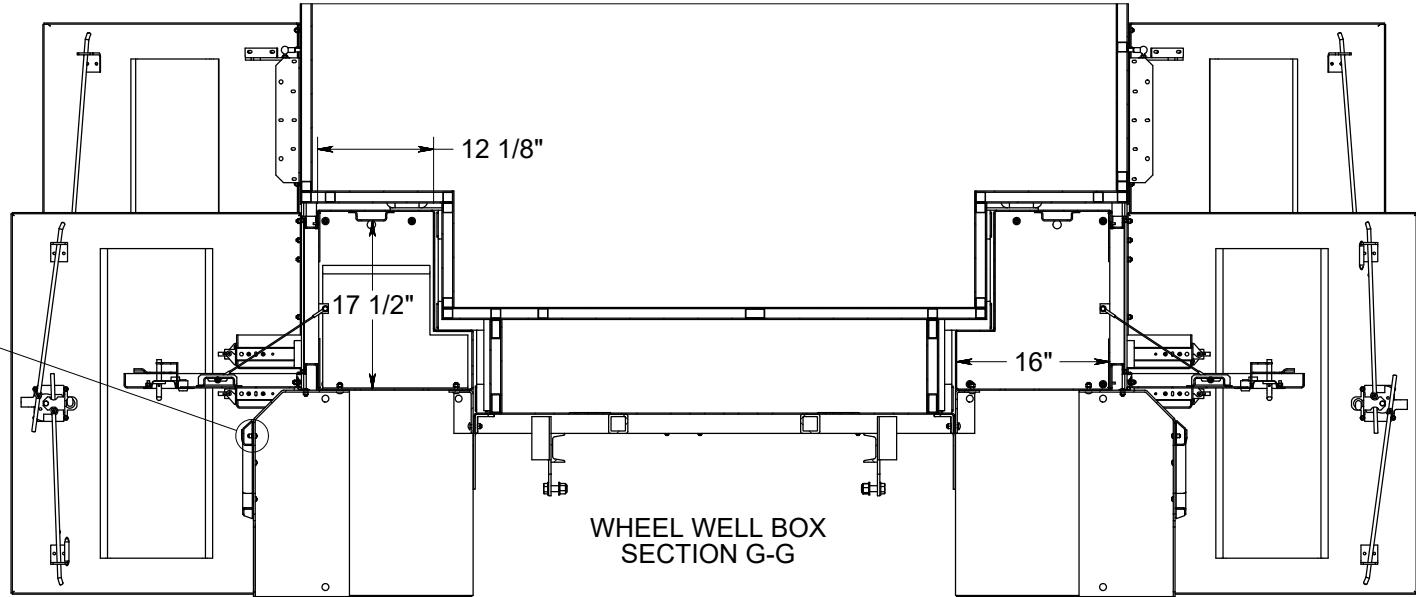

WHEEL WELL BOX
SECTION G-G

22 5/8"
TIRE WIDTH
CLEAR

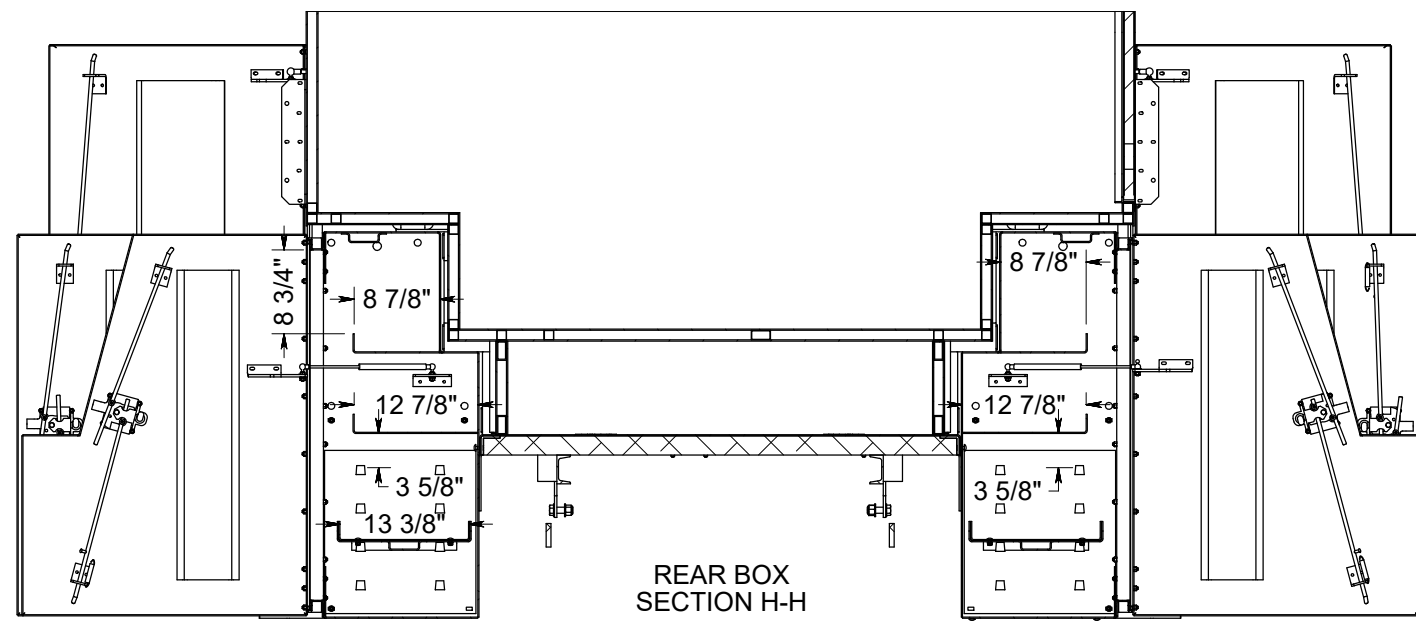

REAR BOX
SECTION H-H

APPROVAL SIGNATURE _____

ESTIMATED LEAD TIME DOES NOT START UNTIL WE RECEIVE THIS
PRINT WITH YOUR APPROVAL SIGNATURE ON IT WITH NO CHANGES

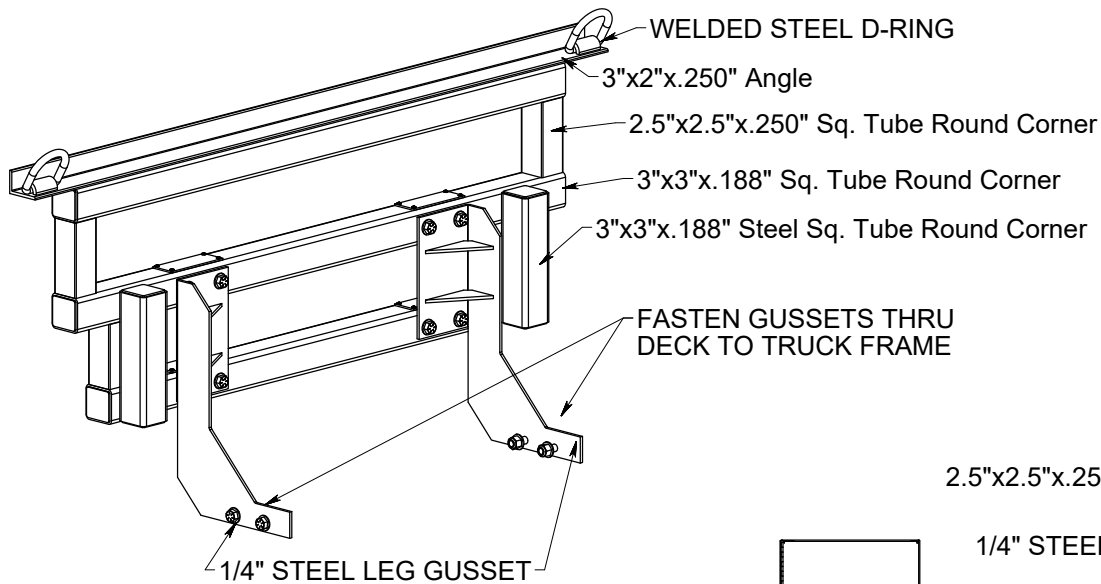

FRONT CAMPER MOUNT

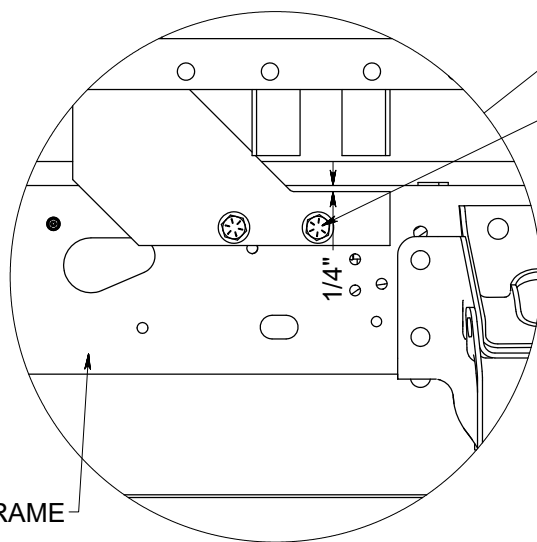
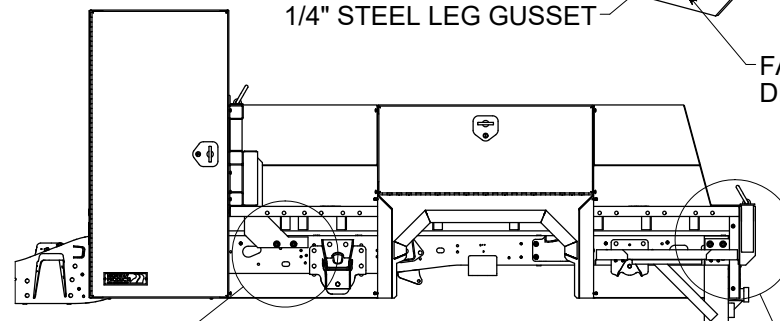
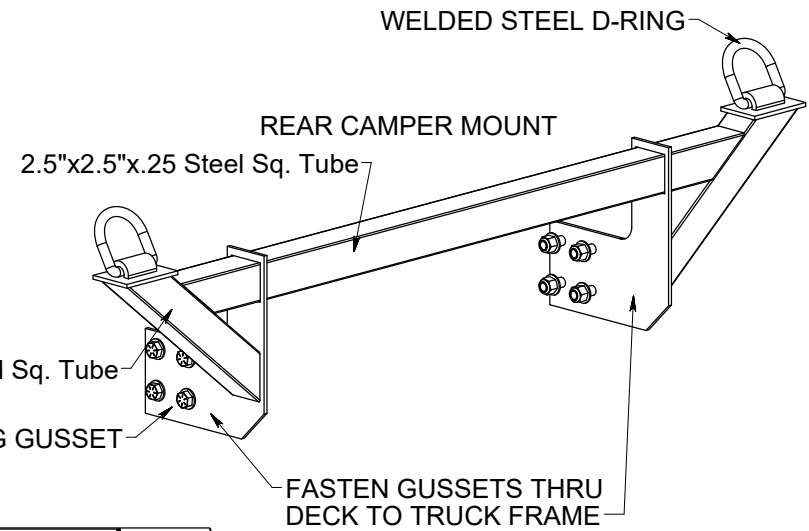

DETAIL K
FRONT MOUNT FASTEN TO FRAME
SCALE 1 : 8

Bolt Steel 5/8"-11 x 2" Hex Bolt Grade 8

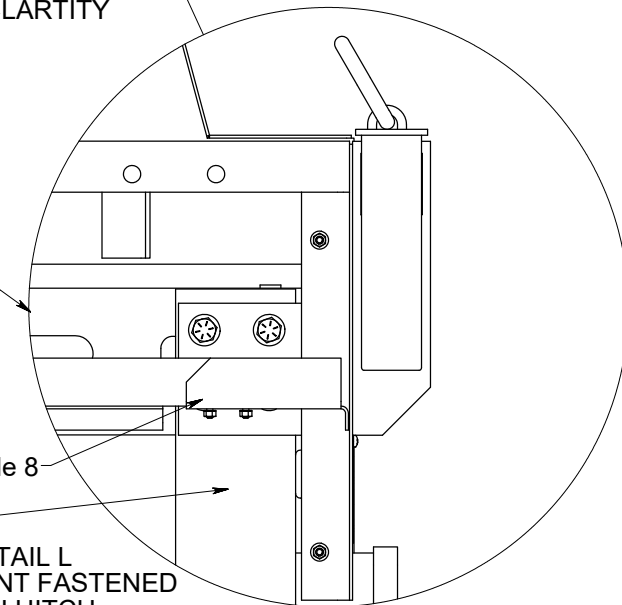

DETAIL L
REAR MOUNT FASTENED THRU HITCH
SCALE 1 : 8

Bolt Steel 5/8"-11 x 2" Hex Bolt Grade 8

APPROVAL SIGNATURE _____

ESTIMATED LEAD TIME DOES NOT START UNTIL WE RECEIVE THIS PRINT WITH YOUR APPROVAL SIGNATURE ON IT WITH NO CHANGES

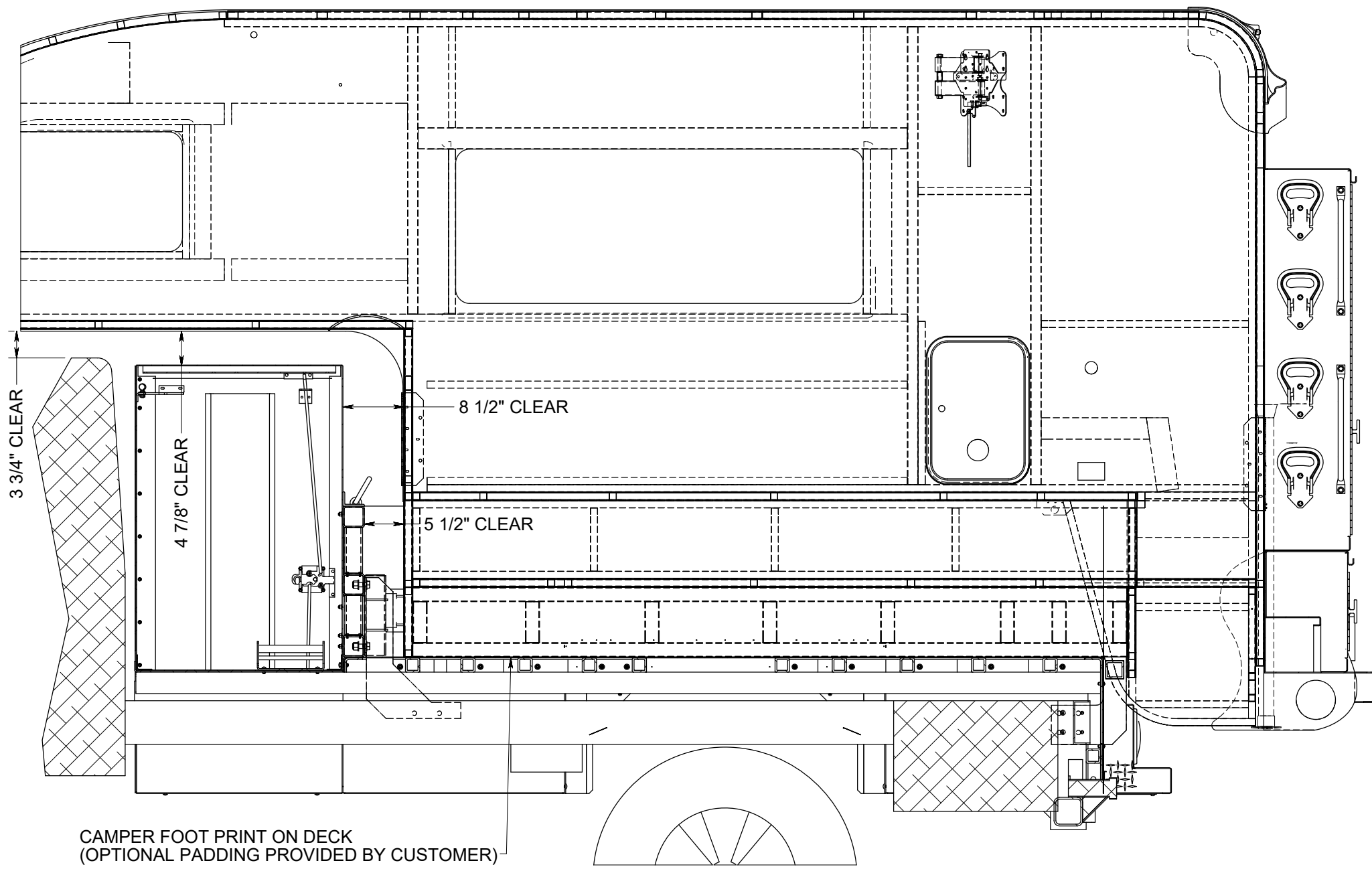

CAMPER FOOT PRINT ON DECK
(OPTIONAL PADDING PROVIDED BY CUSTOMER)

SIDE VIEW SECTION

APPROVAL SIGNATURE _____

ESTIMATED LEAD TIME DOES NOT START UNTIL WE RECEIVE THIS
PRINT WITH YOUR APPROVAL SIGNATURE ON IT WITH NO CHANGES