

WARNING: RAIL (9059-99-061) HAS NO STURCTURAL VALUE & SHOULD NOT BE USED AS A TIE-DOWN POINT.

NOTE: COXREEL SLPF-650 PROVIDED & INSTALLED BY CUSTOMER. REEL SHOWN FOR FITMENT.

TRUCK SPECIFICATIONS
 2020 DODGE 5500 CHASSIS CAB
 CA= 84"
 FRAME AFT OF AXLE=47.5"
 FRAME WIDTH= 34"
 TIRE SIZE= 32"

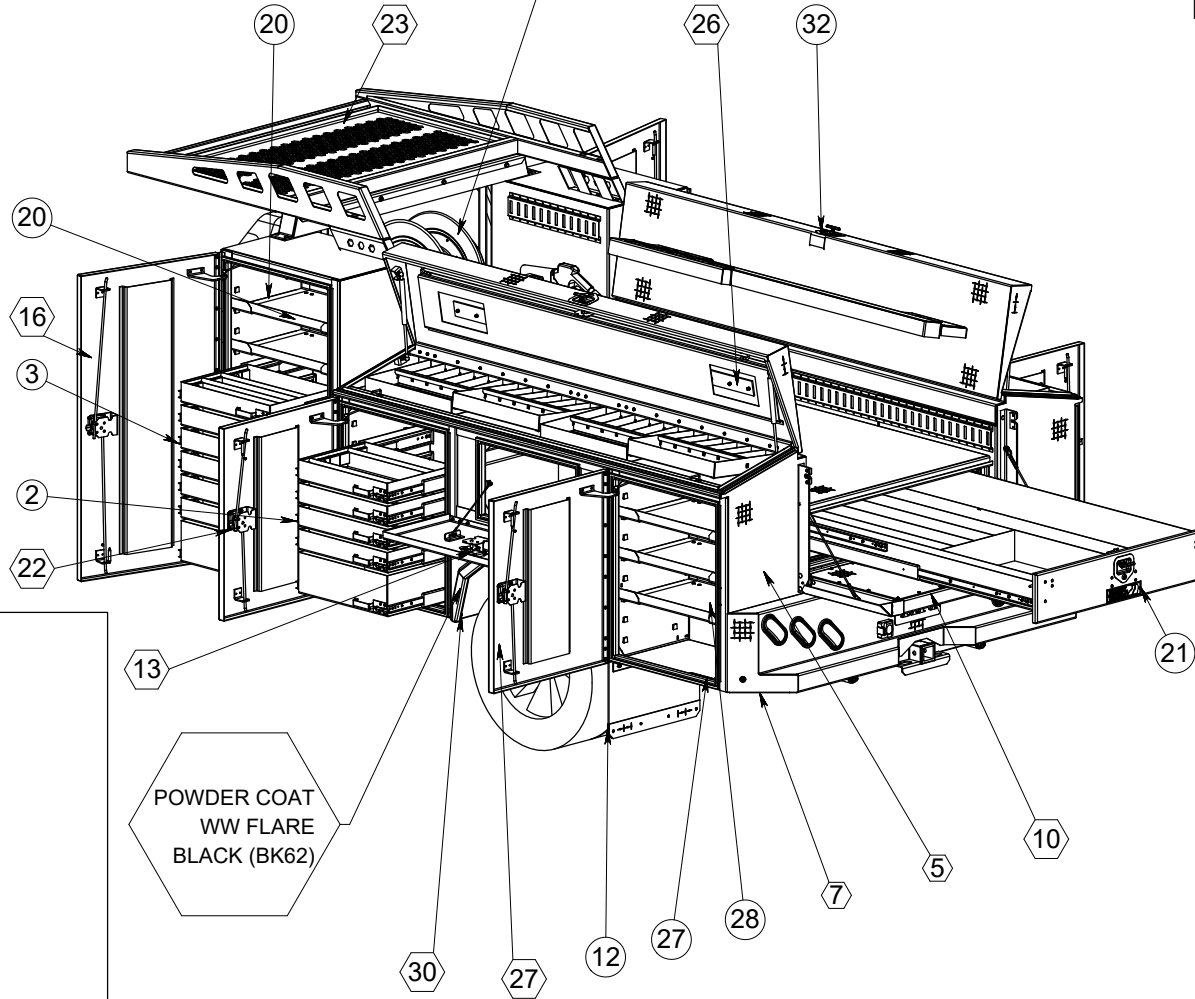

FRAME EXTENSION & HITCH NOT INCLUDED IN BoM

FINISH NOTES	
#	POWDER COAT & SHAVED
#	POWDER COAT
#	RAW or N/A
#	LINE-X
#	PAINT
#	PRIMER
**	SPECIAL NOTE

ITEM NO.	Assembly Desc	Project Number	QTY	FINISH
1	2 DRAWER SLIDE	9059-19-121	1	
2	5 STACK DRAWER SLIDE	9059-19-124	1	
3	7 STACK DRAWER SLIDE	9059-19-123	1	
4	8" SINGLE DRAWER	9059-19-122	1	
5	BACK OVERLAY KIT	590-13-002	1	PSS-4369
6	BTM BOXES LIGHT KIT	590-00057	2	
7	BUMPER	590-06-002	1	BK 62
8	CAB GUARD	9059-09-038	1	-
9	CORNER LIGHT BOX KIT, CLEAR	550-02-018	1	
10	CUSTOM TAILGATE	9059-05-033	1	PSS-4369
11	DECK	9059-04-064	1	
12	DP MUD FLAP	550-18-008	2	
13	DS WW BOX	590-02-003	1	PSS-4369 DR
14	E-TRACK LOWER	040-25045	2	
15	E-TRACK UPPER	040-25045	2	
16	FRONT BOX	9059-01-061	1	PSS-4369 DR
17	FRONT BRACE	590-17-002	1	PSS-4369 DR
18	FRONT OVERLAY KIT	590-13-003	1	
19	FRONT TOP OVERLAY KIT	9059-13-100	1	PSS-4369
20	FRONT SHELF	9059-11-012	3	
21	LOCK UP BOX	9042-346	1	
22	MID BOX	9059-01-045	1	PSS-4369 DR
23	OVERHEAD RACK	9059-10-062	1	BK62
24	PS FRONT SHELF	9059-11-062	4	
25	PS WW BOX	590-02-004	1	PSS-4369 DR
26	RAIL	9059-99-061	1	BK62
27	REAR BOX	590-03-002	1	PSS-4369 DR
28	REAR SHELF	590-11-005	6	
29	SINGLE LID TOP BOX LIGHT KIT	590-00058	2	
30	SKIRT SET	9059-16-028	1	PSS-4369 / BK62
31	TANK	9023-273	1	
32	TOP BOX	9059-07-055	2	PSS-4369 DR
33	TRAY	590-18-006	8	

MATERIAL:		ALUMINUM		PROJECT #:	3412
FINISH:		DP & SMOOTH			
REVISION:	APVL BY:	ENG DATE:			
AA	DAL	09/30/2020			
Ov1					

HIGHWAY PRODUCTS
 1-800-TOOL BOX
 FAX 1-800-465-9545
 800TOOLBOX.COM

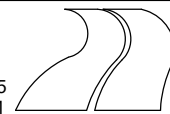

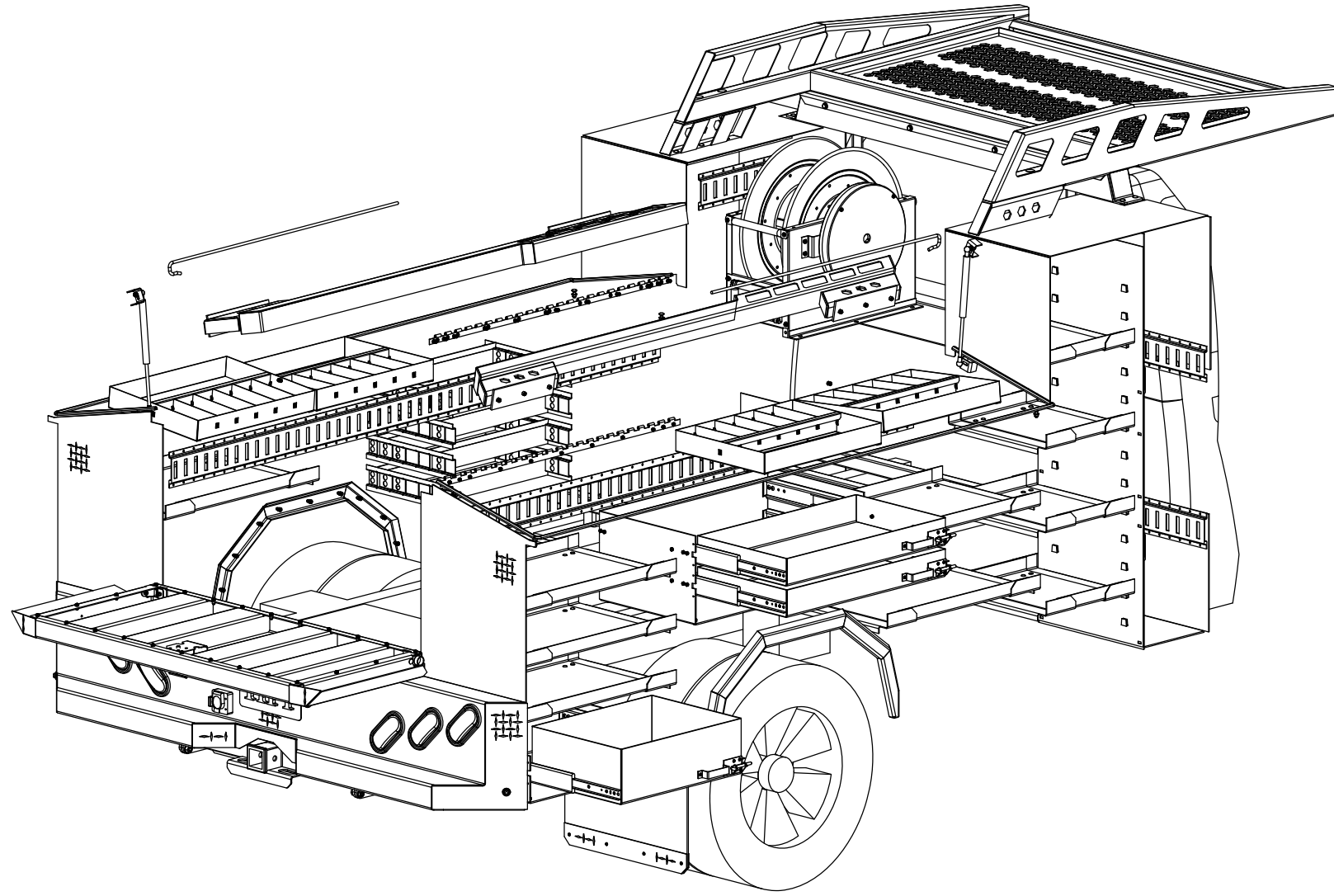

PS ISOMETRIC VIEW WITH THE DOORS OPEN

APPROVAL SIGNATURE _____

ESTIMATED LEAD TIME DOES NOT START UNTIL WE RECEIVE THIS PRINT WITH YOUR APPROVAL SIGNATURE ON IT WITH NO CHANGES

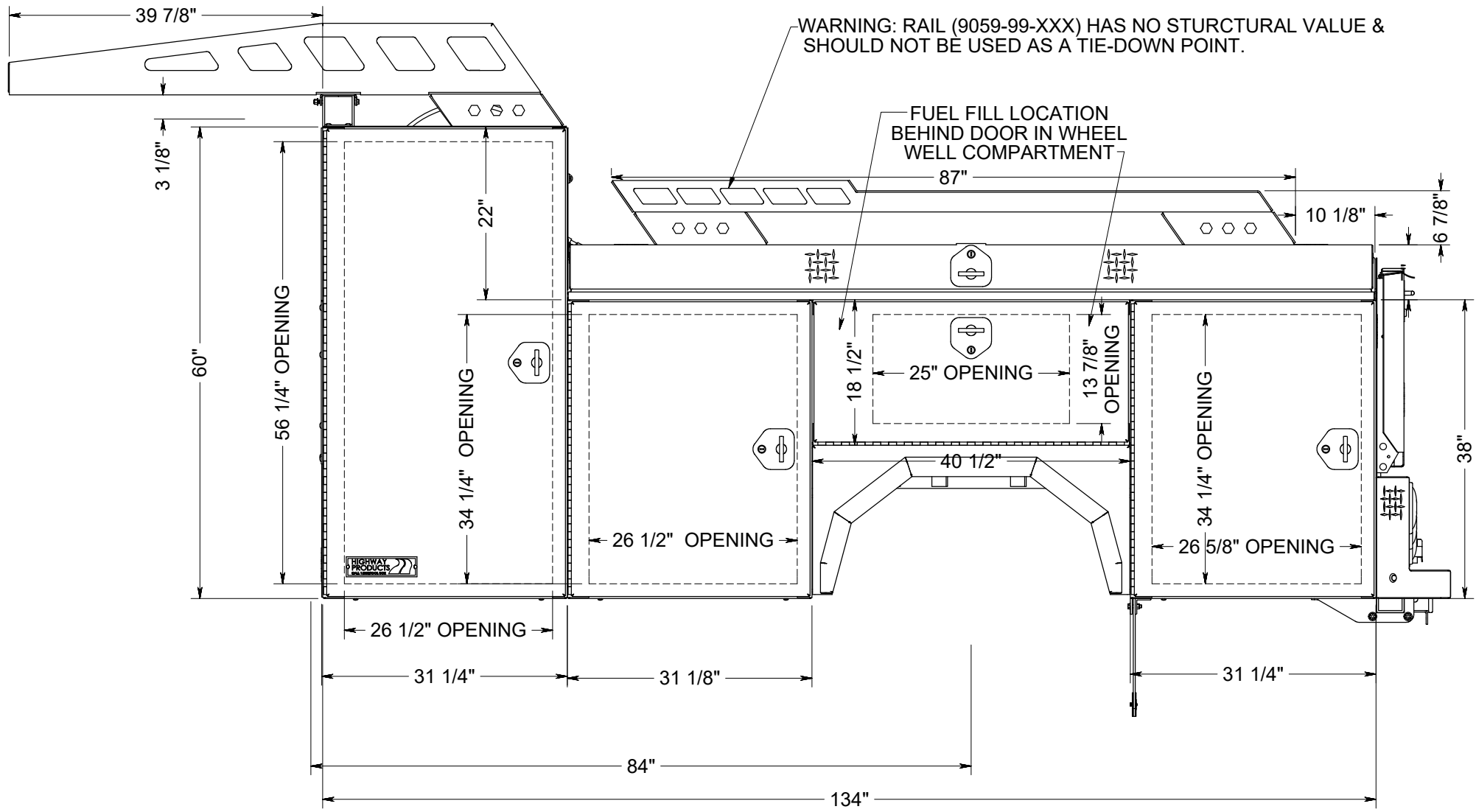

DS VIEW

APPROVAL SIGNATURE _____

ESTIMATED LEAD TIME DOES NOT START UNTIL WE RECEIVE THIS PRINT WITH YOUR APPROVAL SIGNATURE ON IT WITH NO CHANGES

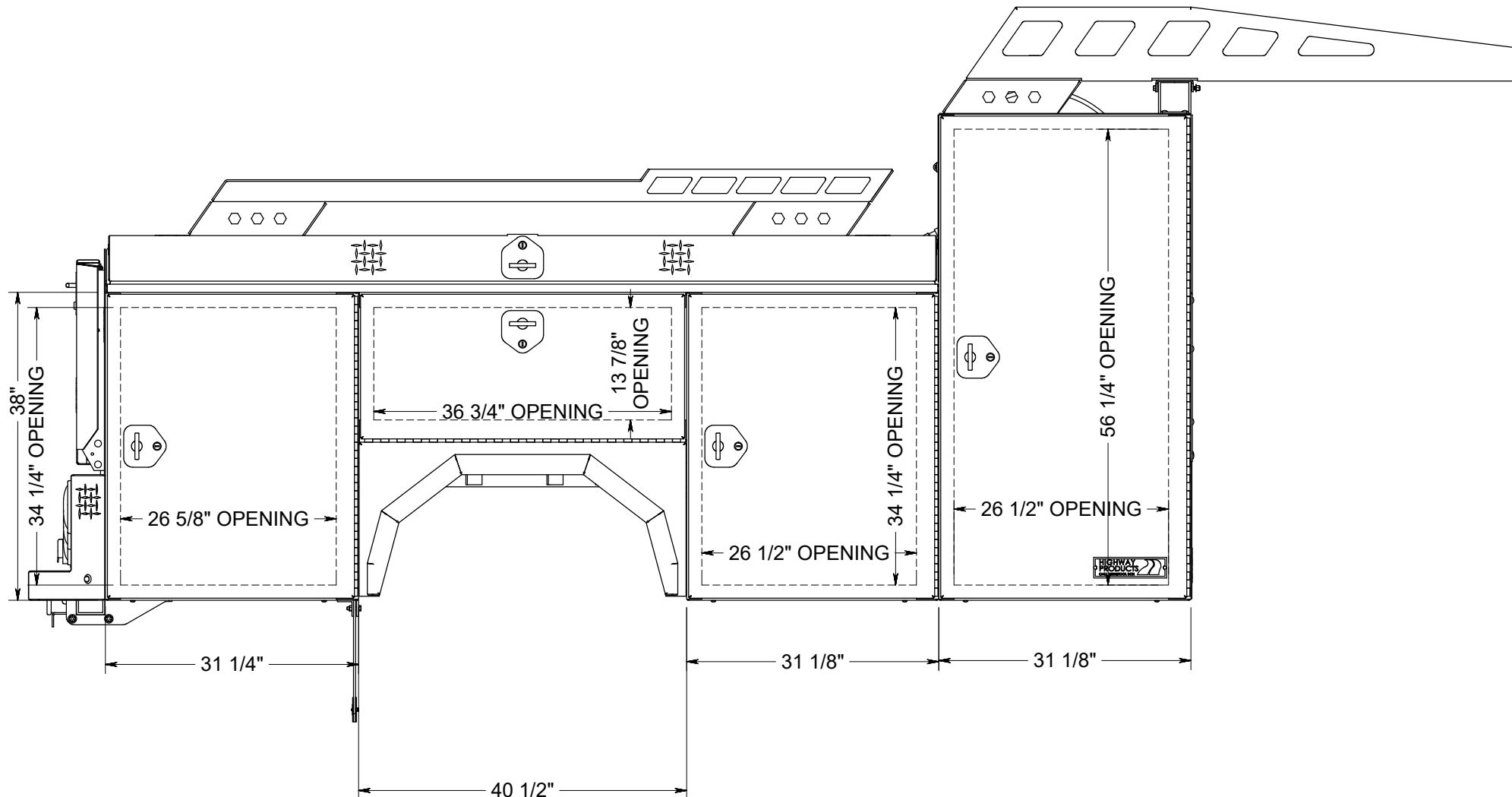

PS VIEW

APPROVAL SIGNATURE _____

ESTIMATED LEAD TIME DOES NOT START UNTIL WE RECEIVE THIS PRINT WITH YOUR APPROVAL SIGNATURE ON IT WITH NO CHANGES

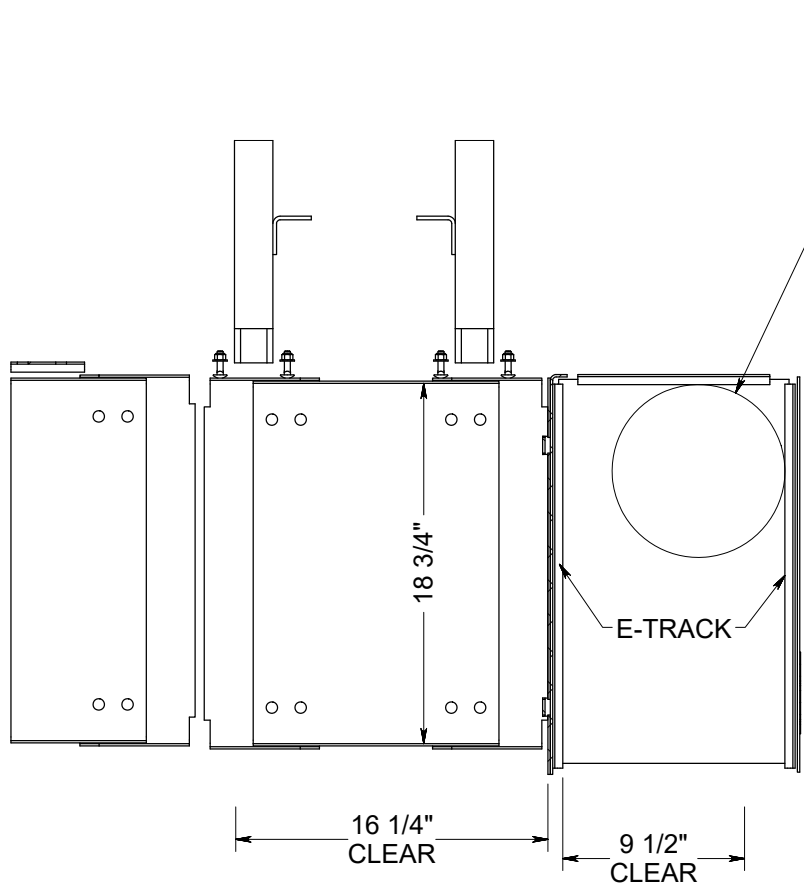

PS FRONT BOX TOP SECTION G-G SCALE 1 : 10

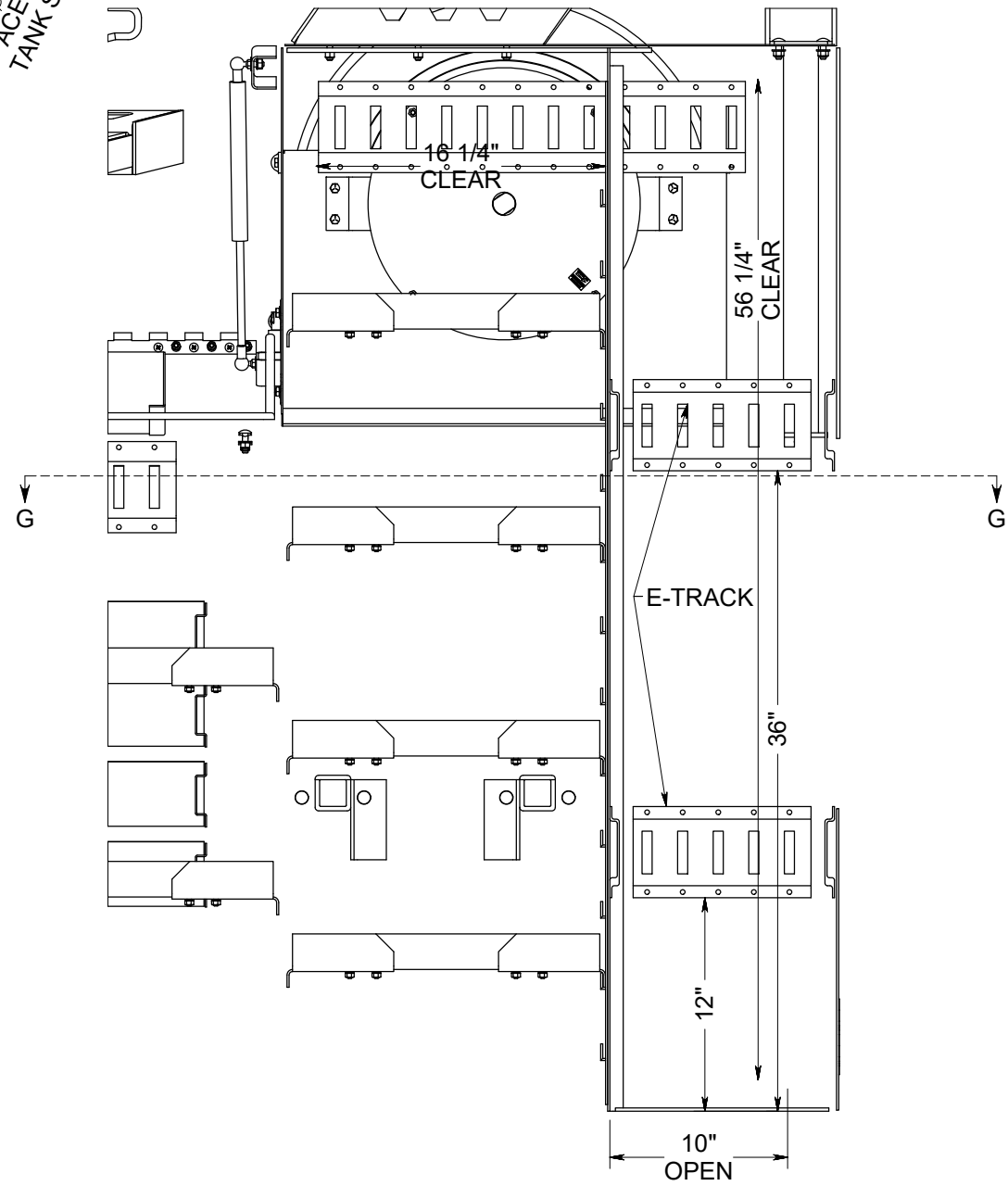

PS FRONT BOX DETAIL

APPROVAL SIGNATURE _____

ESTIMATED LEAD TIME DOES NOT START UNTIL WE RECEIVE THIS PRINT WITH YOUR APPROVAL SIGNATURE ON IT WITH NO CHANGES

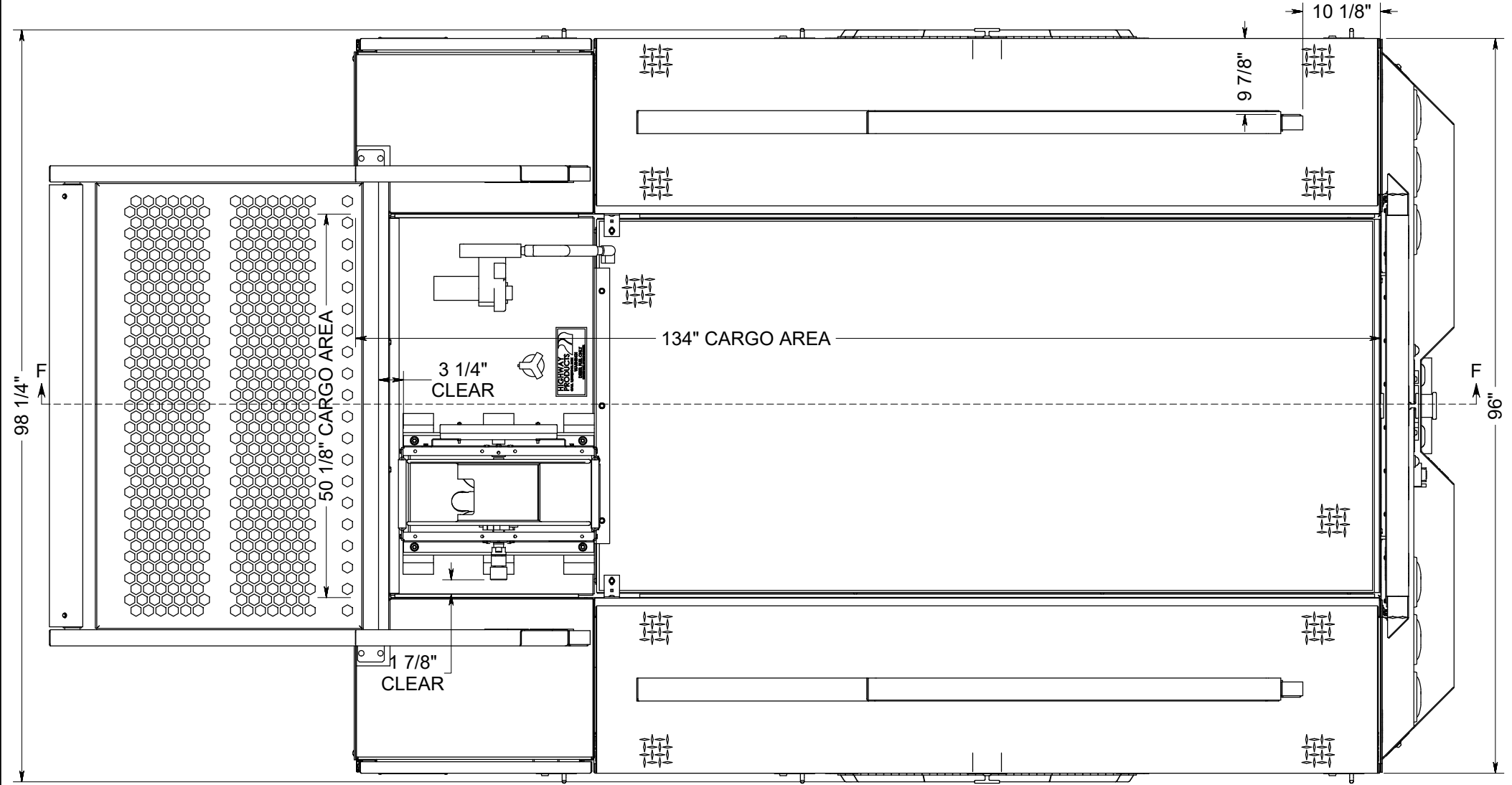

APPROVAL SIGNATURE _____

TOP VIEW

ESTIMATED LEAD TIME DOES NOT START UNTIL WE RECEIVE THIS PRINT WITH YOUR APPROVAL SIGNATURE ON IT WITH NO CHANGES

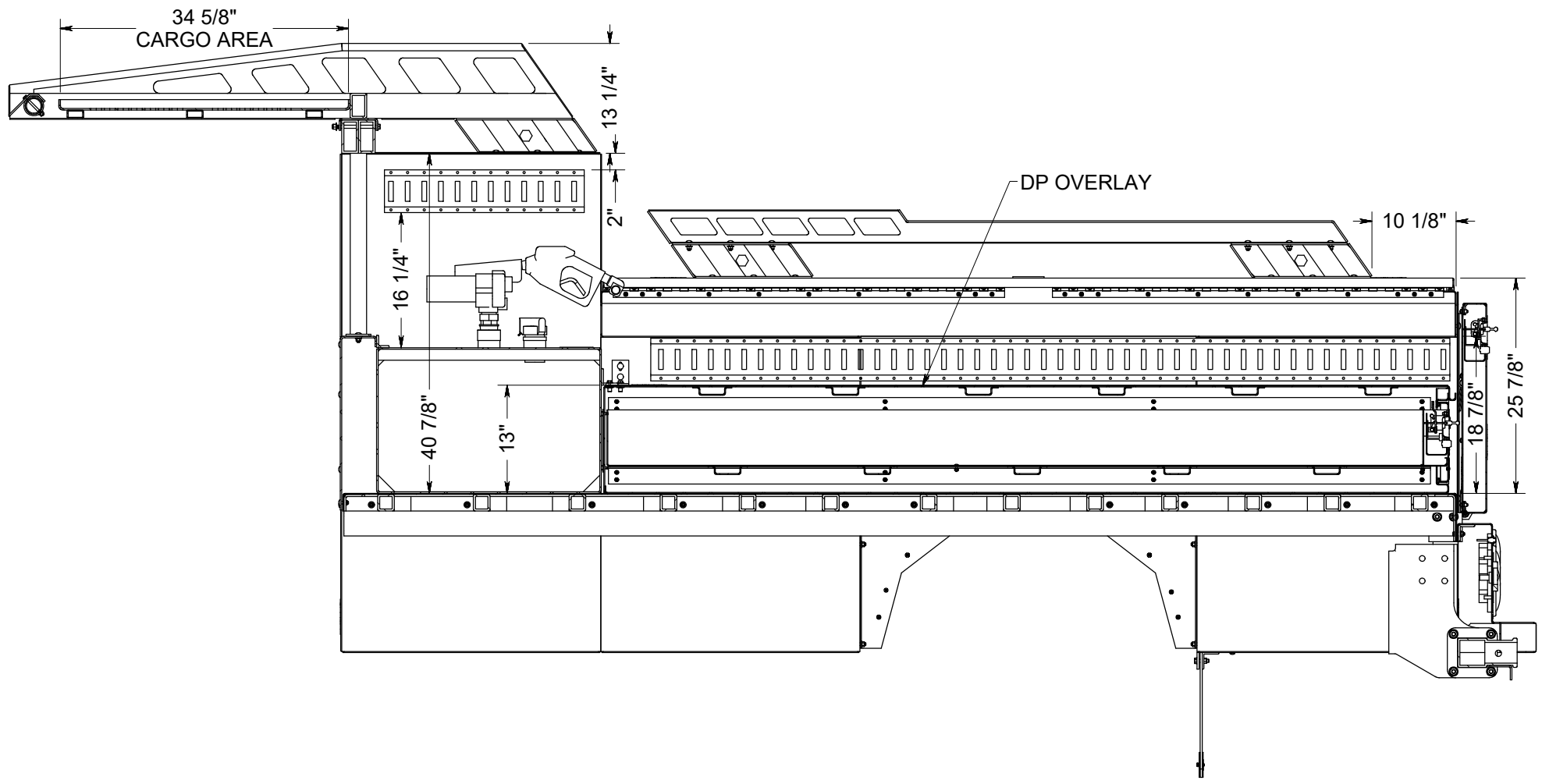

SIDE SECTION F-F
SCALE 1 : 18

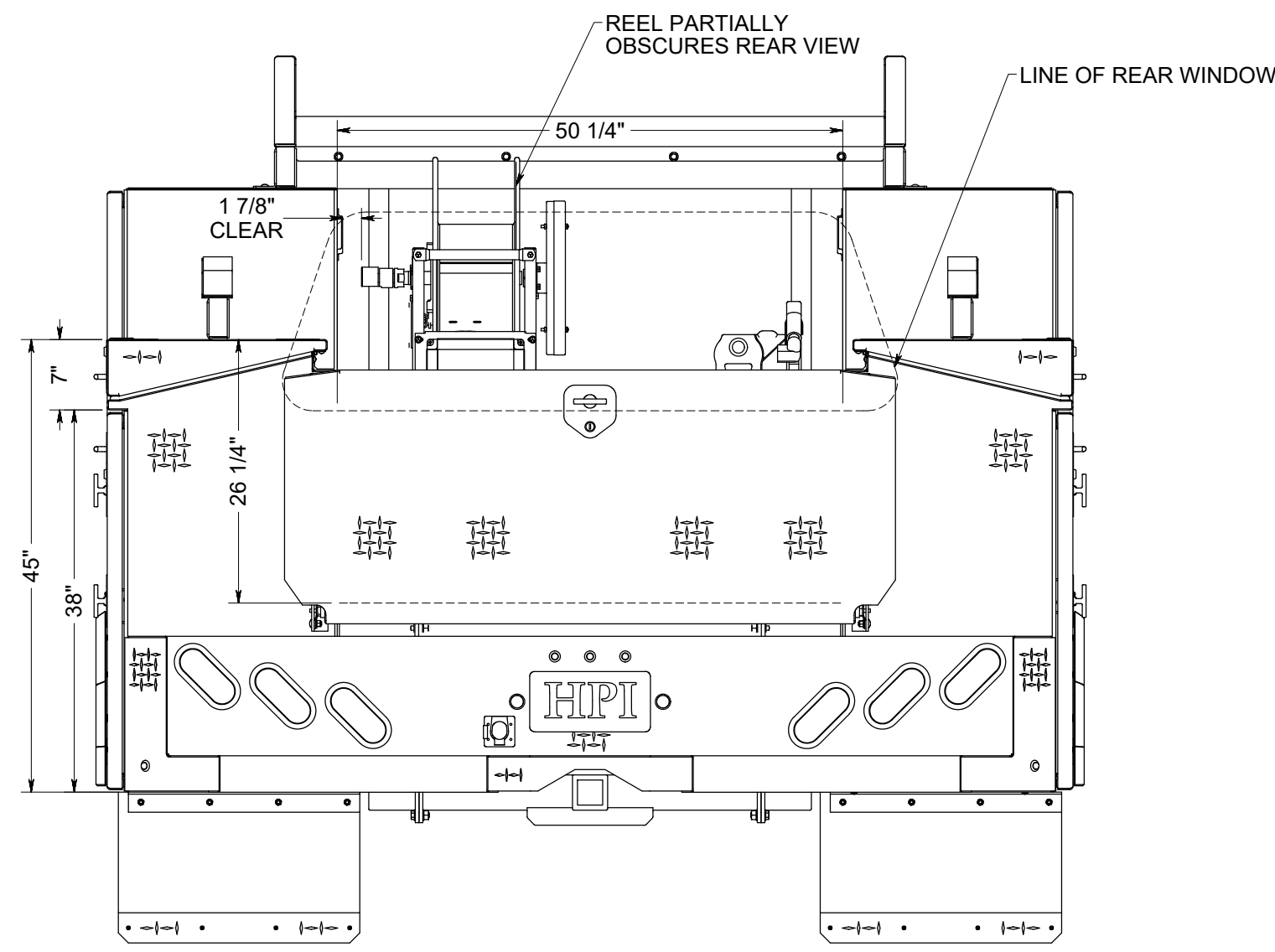

APPROVAL SIGNATURE _____

ESTIMATED LEAD TIME DOES NOT START UNTIL WE RECEIVE THIS PRINT WITH YOUR APPROVAL SIGNATURE ON IT WITH NO CHANGES

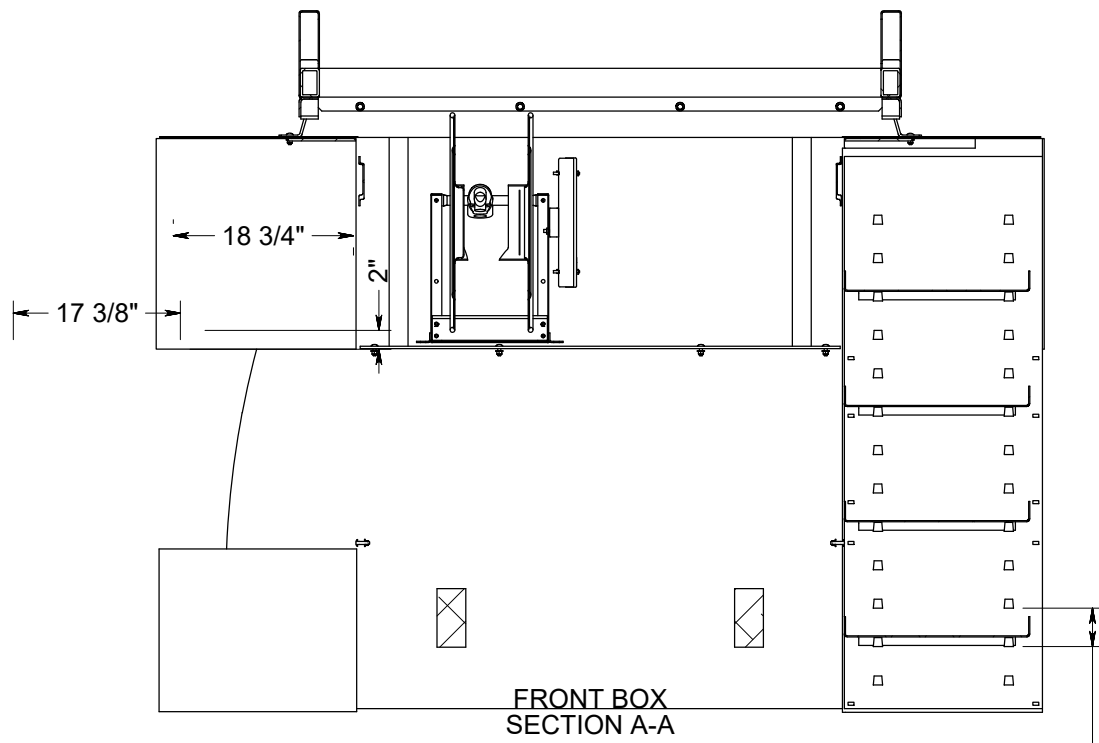

FRONT BOX SECTION A-A

4" TYP SHELF ADJUSTMENT

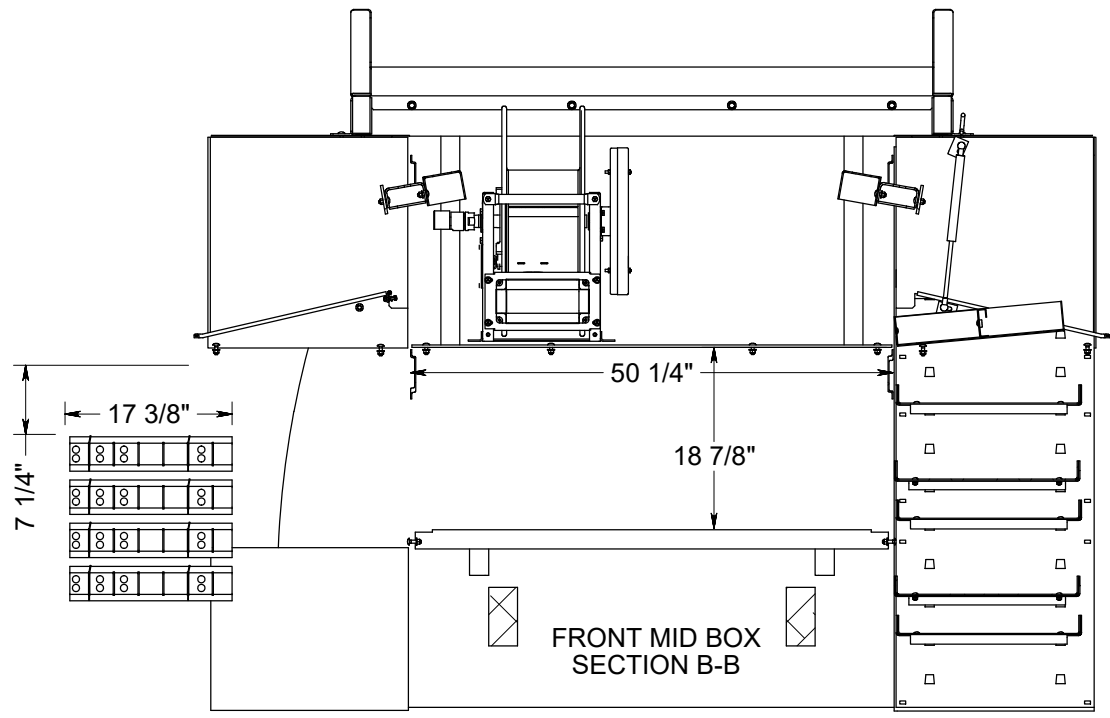

FRONT MID BOX SECTION B-B

APPROVAL SIGNATURE _____

ESTIMATED LEAD TIME DOES NOT START UNTIL WE RECEIVE THIS PRINT WITH YOUR APPROVAL SIGNATURE ON IT WITH NO CHANGES

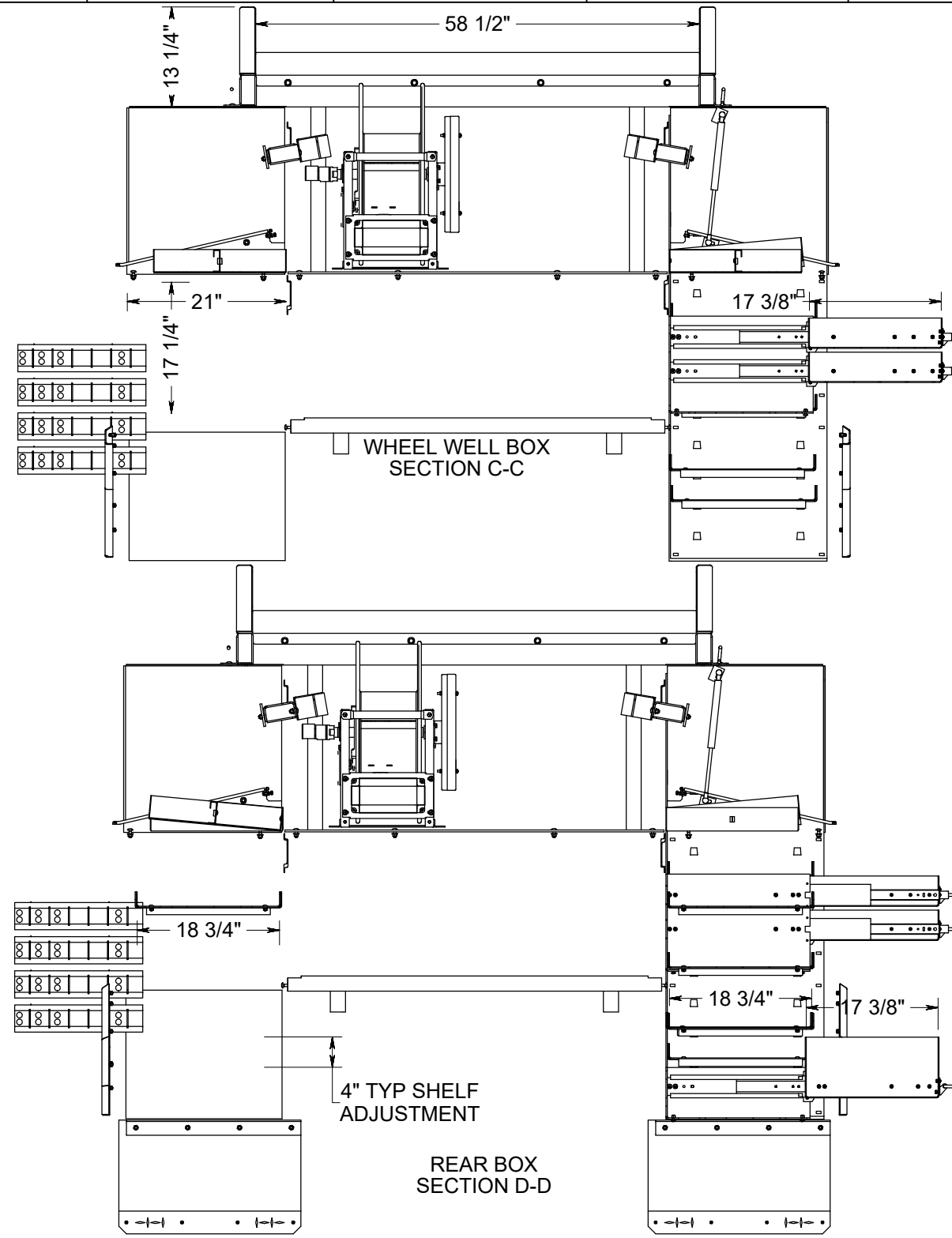

APPROVAL SIGNATURE _____
ESTIMATED LEAD TIME DOES NOT START UNTIL WE RECEIVE THIS
PRINT WITH YOUR APPROVAL SIGNATURE ON IT WITH NO CHANGES

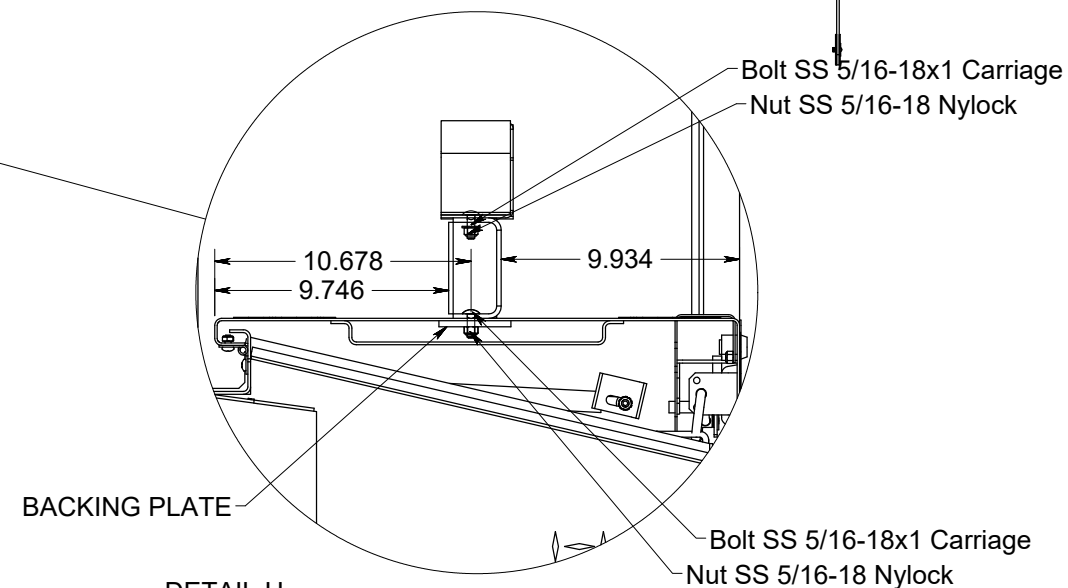
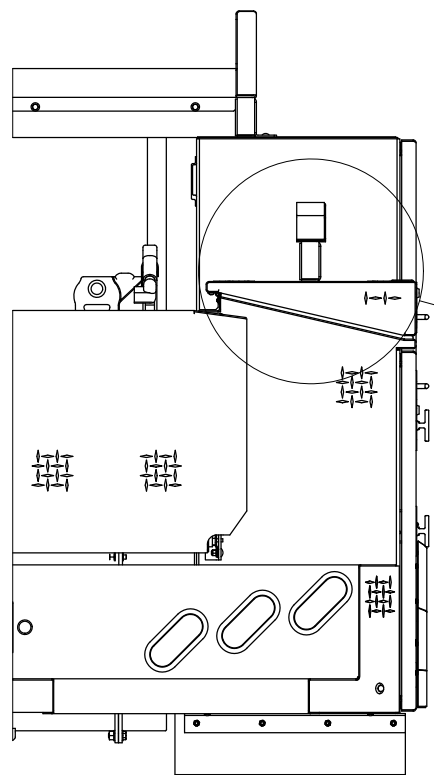
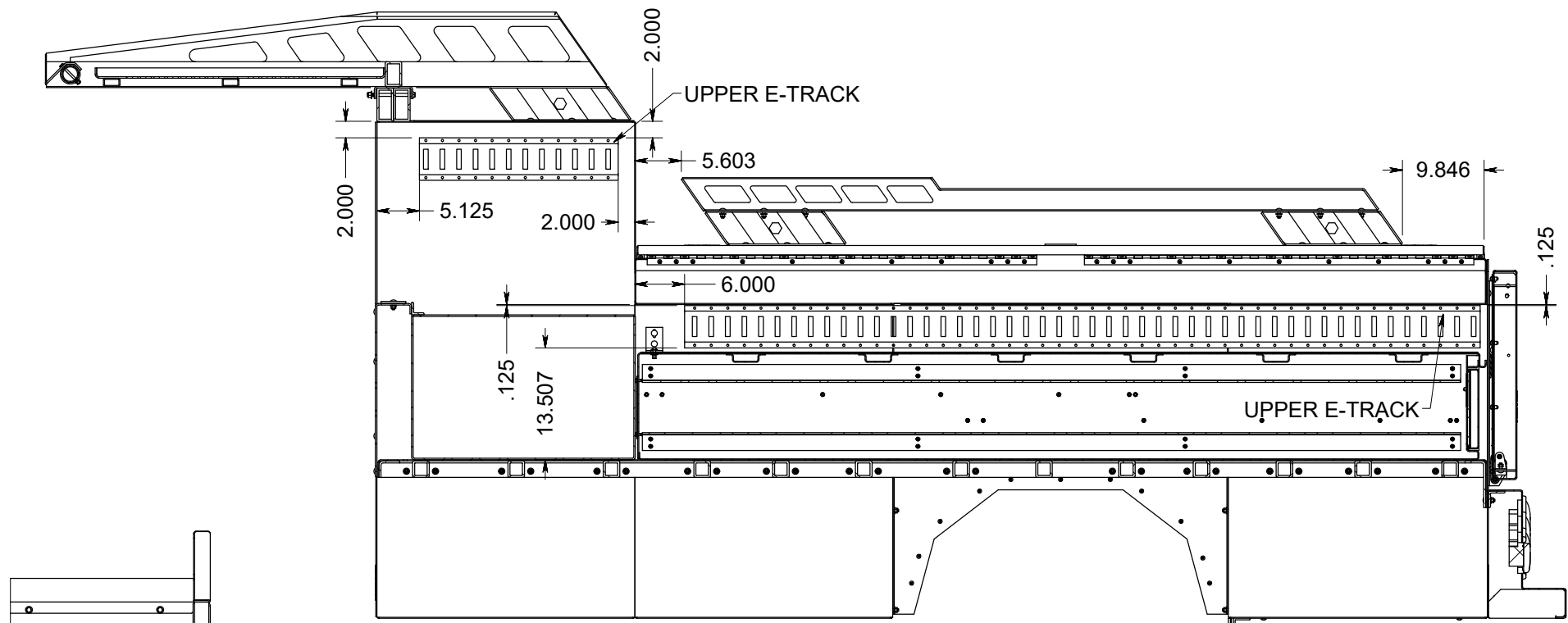

DETAIL H
SCALE 1 : 8