

ITEM NO.	Assembly Desc	Project Number	QTY	FINISH
1	FRONT BRACE	590-17-001	1	RAW
2	SKIRT SET	590-16-003	1	070-PSB-8051
3	DECK	9059-04-057	1	RAW
4	FRONT SHELF	590-11-001	4	RAW
5	PS & DS FRONT, MID, REAR BOXES	590-21-001	1	070-PSB-8051
6	3 DRAWER STACK	590-19-002	1	RAW
7	AL E-TRACK	040-25045	242"	070-PSB-8051
8	DUAL LID TOP BOX LIGHT KIT	590-00069	1	N/A
9	BTM BOXES LIGHT KIT	590-00057	1	N/A
10	STEP	535-00034	2	RAW
11	TOMMY GATE	S.O. SPECIFIED	1	N/A
12	CABGUARD	590-09-001	1	BK62
13	LUMBER RACK	590-10-003,004,005	1	BK62
14	REAR SHELF	590-11-002	2	RAW
15	TOP BOX	590-07-010	2	070-PSB-8051
16	TOP BOX TRAY	590-18-010	4	RAW
17	REAR OVERLAY	9059-13-090	1	070-PSB-8051
18	SUPPORT BRACE	9059-99-060	1	070-PSB-8051

TRUCK SPECIFICATIONS

2020 FORD F-250-350 SRW

BOX DELETE

CA= 56.5"
 FRAME AFT OF AXLE= 40.4"
 FRAME WIDTH= 37.75"
 TIRE SIZE= 32+/- 2"

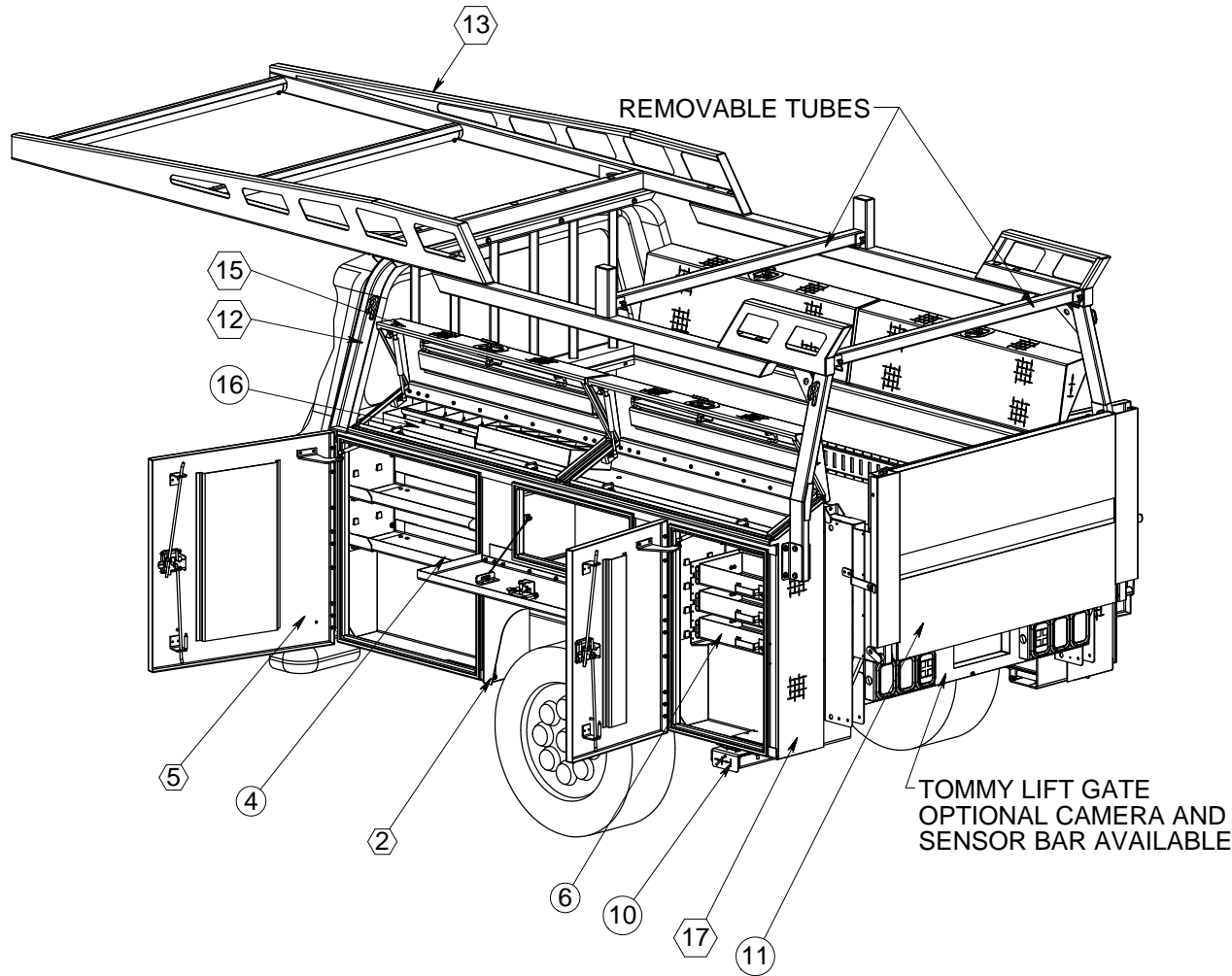

FINISH NOTES	
△ #	POWDER COAT & SHAVED
⬡ #	POWDER COAT
⊙ #	RAW or N/A
⊠ #	LINE-X
◇ #	PAINT
○ #	PRIMER
**	SPECIAL NOTE

MATERIAL: ALUMINUM		PROJECT #: 3450
FINISH: DP & SMOOTH		DRAWN BY:
REVISION: AA	APVL BY: JMG	ENG DATE: 10/13/2020
Ov1		

100" x 36" x 80" SERVICE BODY

HIGHWAY PRODUCTS
 1-800-TOOL BOX
 FAX 1-800-465-9545
 800TOOLBOX.COM



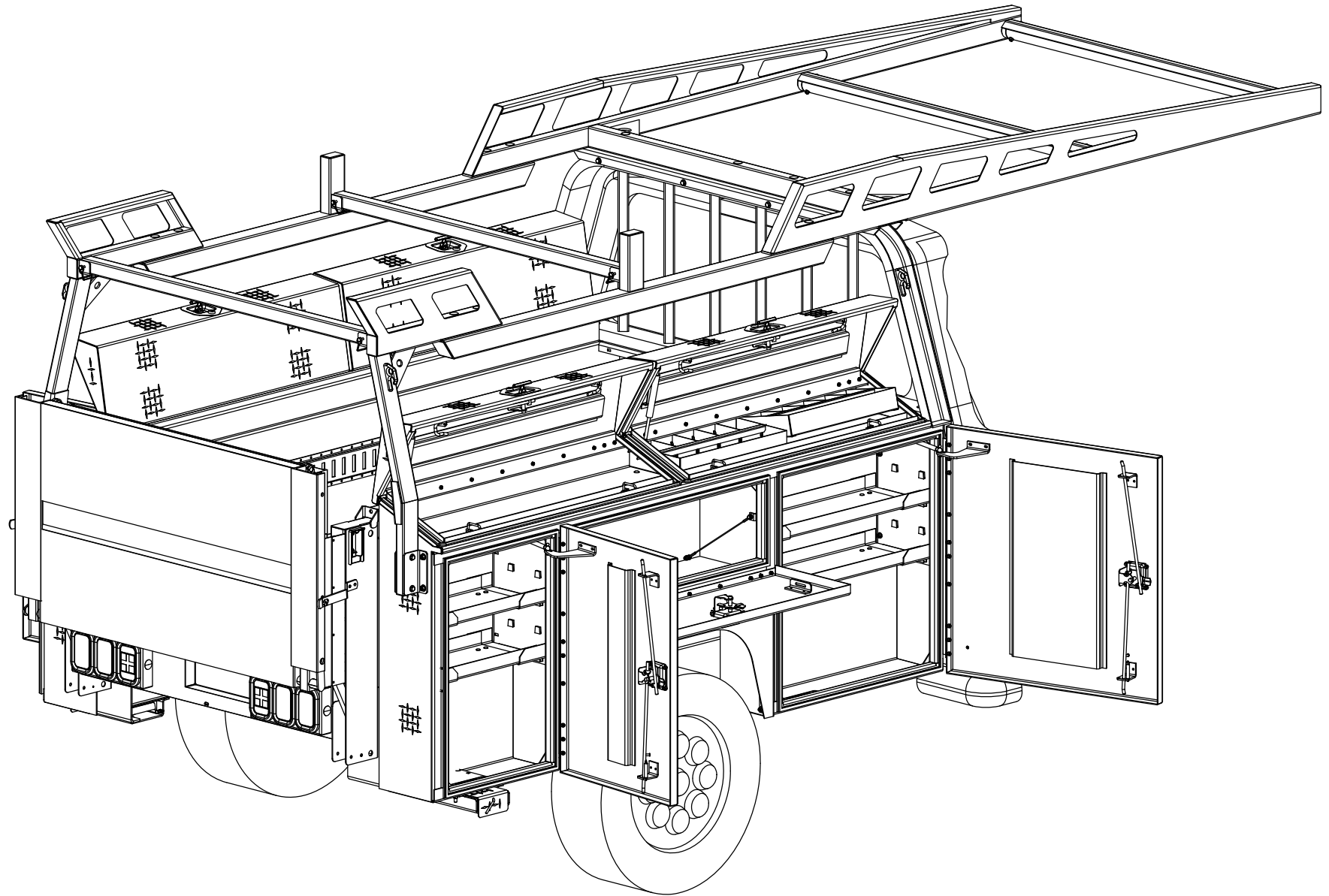

PS ISOMETRIC VIEW WITH THE DOORS OPEN

APPROVAL SIGNATURE _____

ESTIMATED LEAD TIME DOES NOT START UNTIL WE RECEIVE THIS
PRINT WITH YOUR APPROVAL SIGNATURE ON IT WITH NO CHANGES

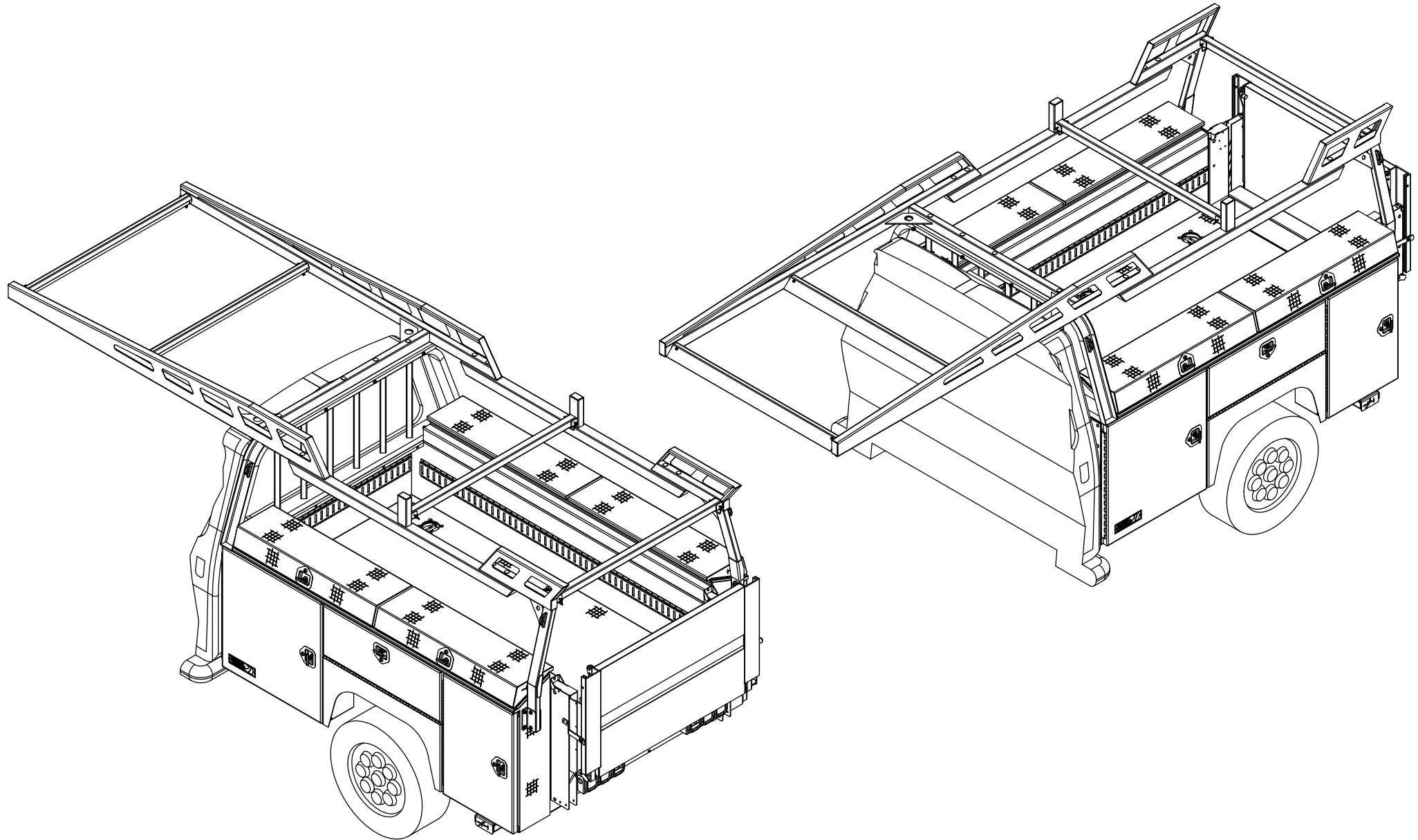

DS ISOMETRIC VIEW WITH THE DOORS CLOSED

APPROVAL SIGNATURE _____

ESTIMATED LEAD TIME DOES NOT START UNTIL WE RECEIVE THIS PRINT WITH YOUR APPROVAL SIGNATURE ON IT WITH NO CHANGES

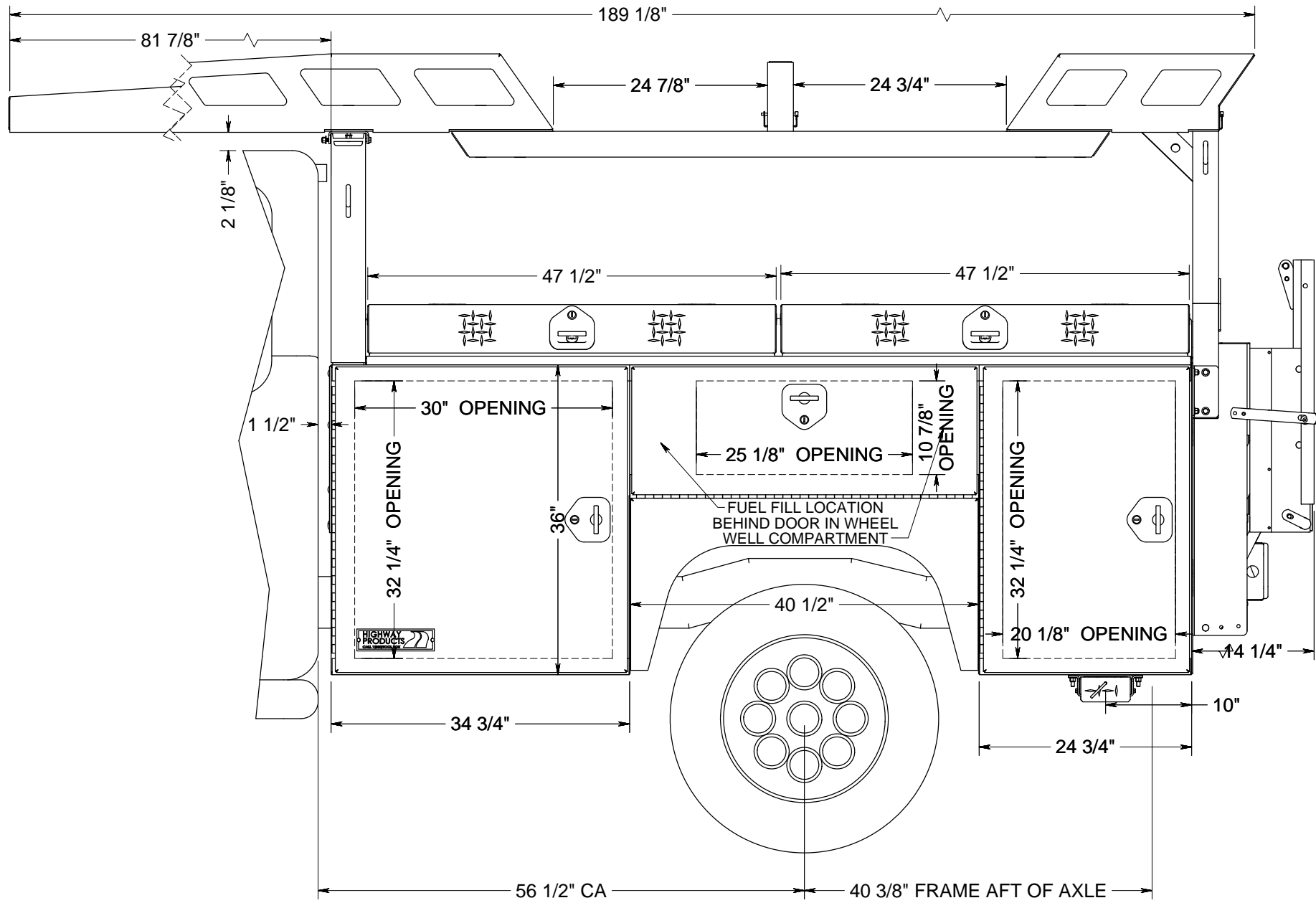

DS VIEW

APPROVAL SIGNATURE _____

ESTIMATED LEAD TIME DOES NOT START UNTIL WE RECEIVE THIS PRINT WITH YOUR APPROVAL SIGNATURE ON IT WITH NO CHANGES

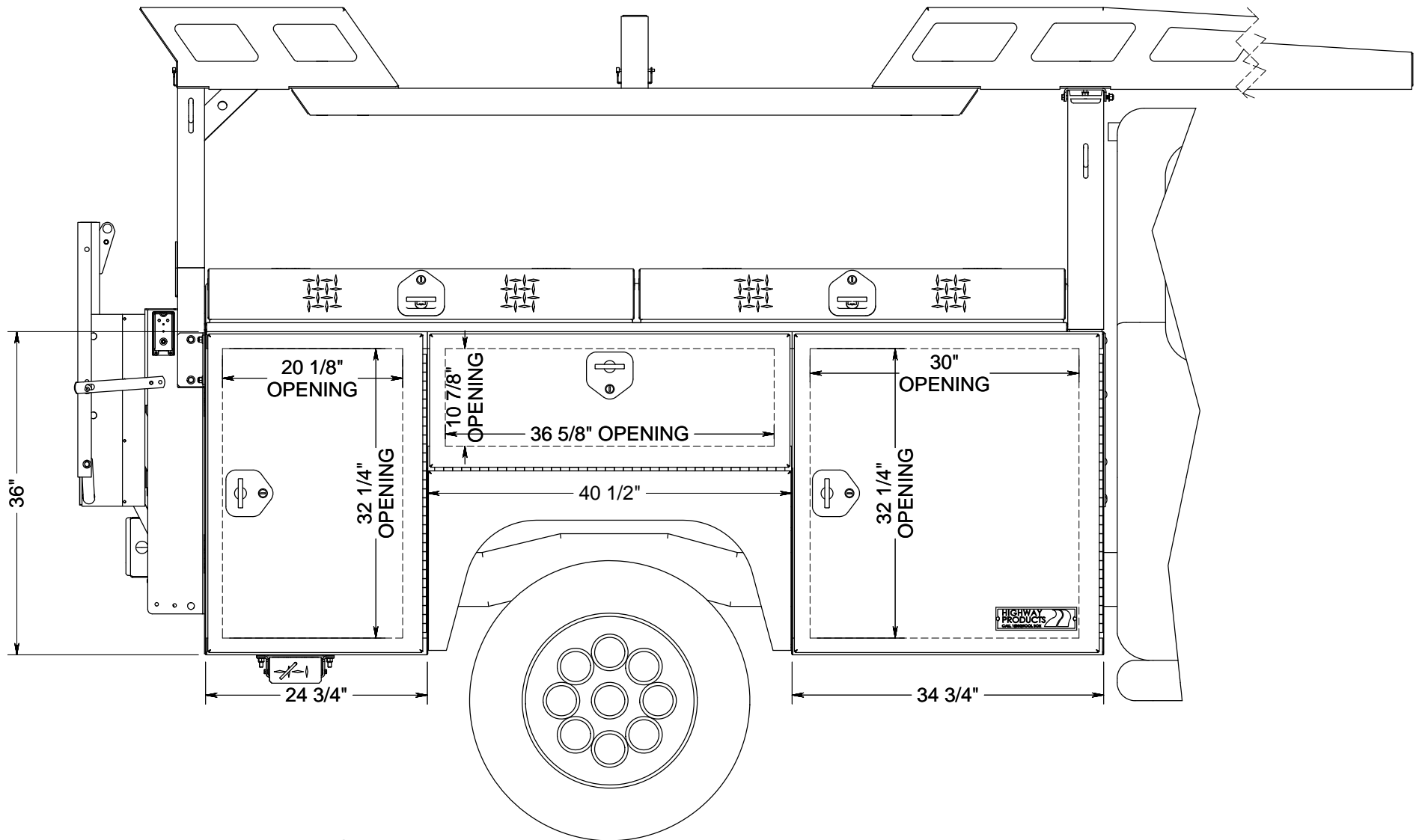

PS VIEW

APPROVAL SIGNATURE _____

ESTIMATED LEAD TIME DOES NOT START UNTIL WE RECEIVE THIS PRINT WITH YOUR APPROVAL SIGNATURE ON IT WITH NO CHANGES

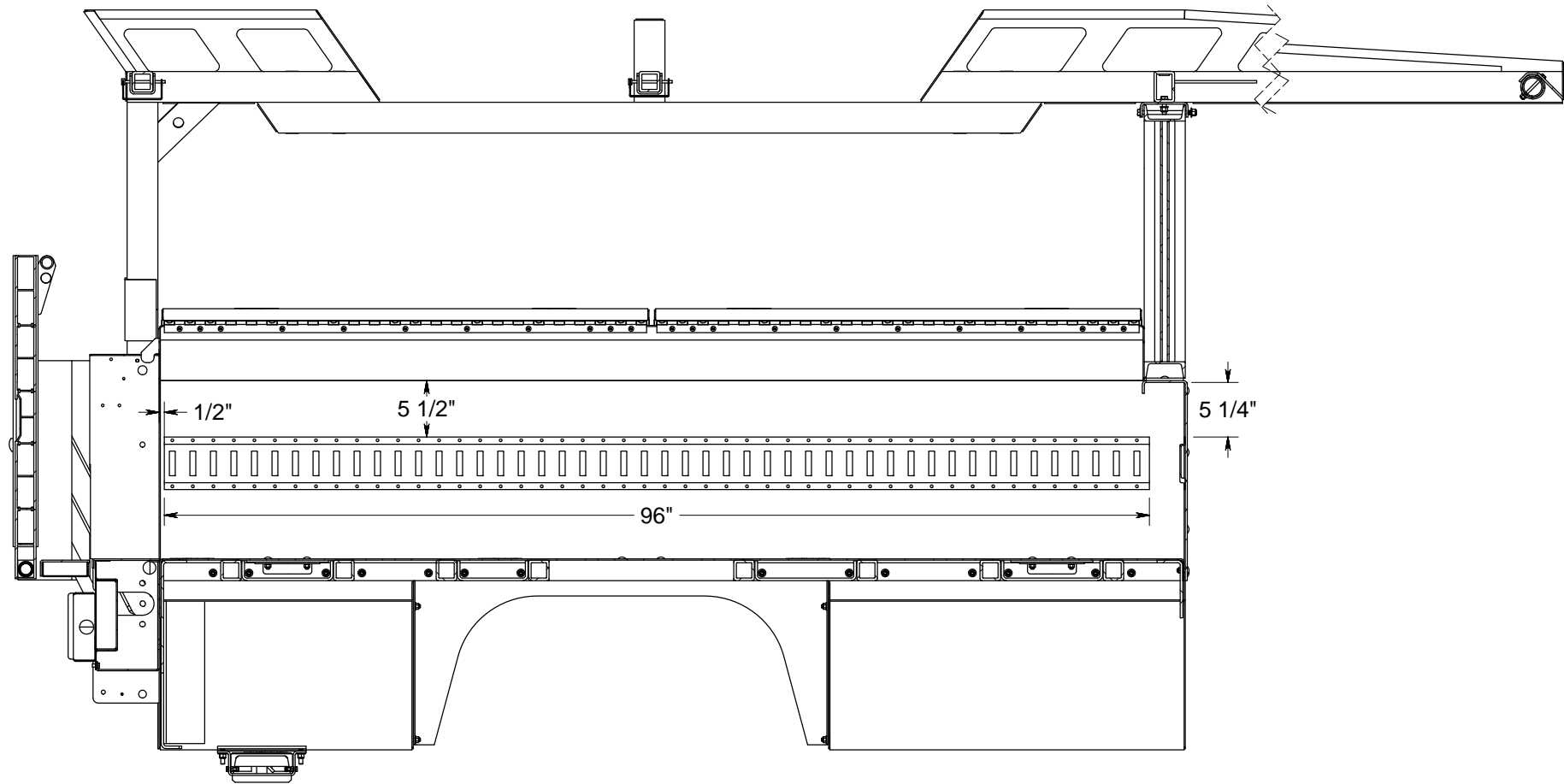

PS SECTION VIEW

APPROVAL SIGNATURE _____

ESTIMATED LEAD TIME DOES NOT START UNTIL WE RECEIVE THIS PRINT WITH YOUR APPROVAL SIGNATURE ON IT WITH NO CHANGES

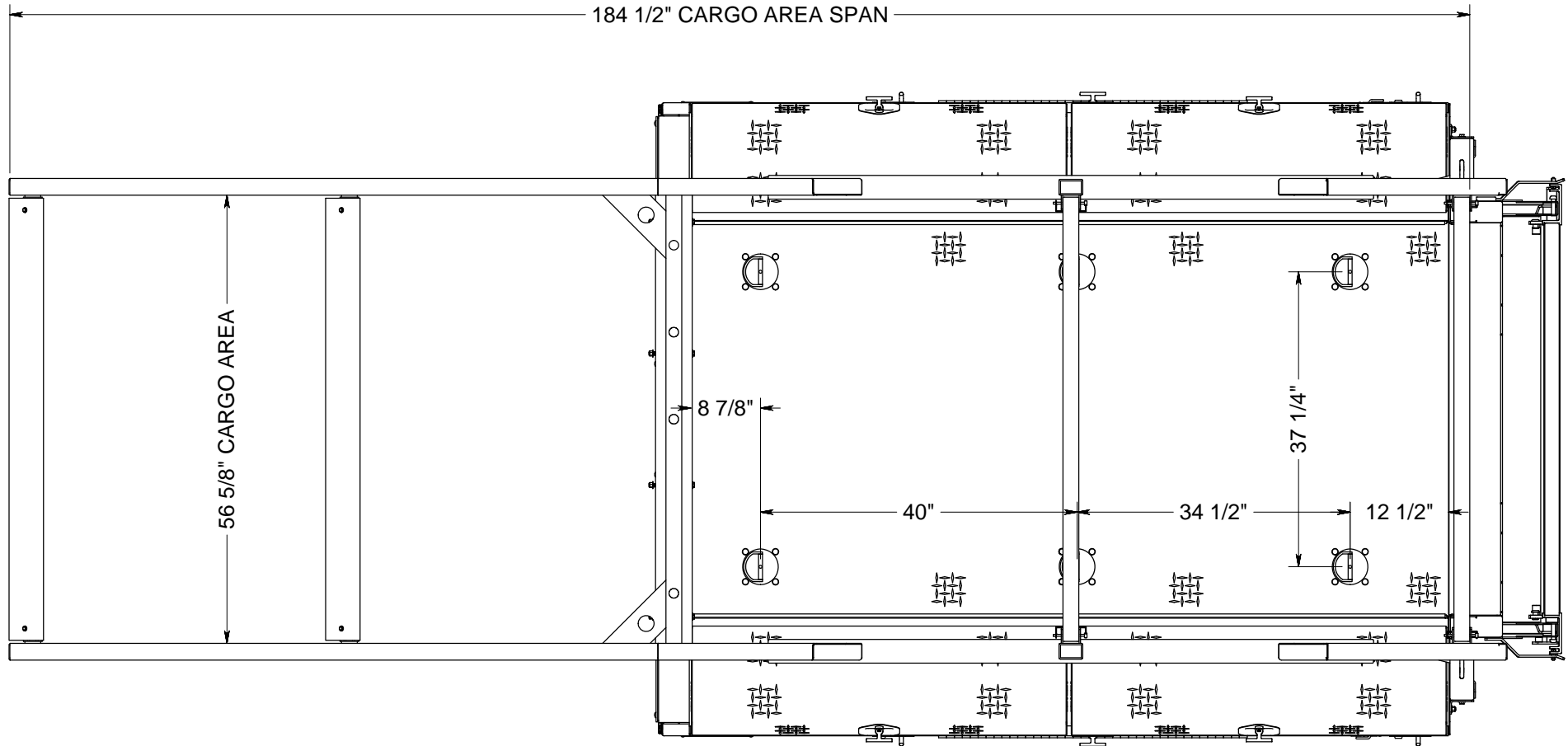

TOP VIEW

APPROVAL SIGNATURE _____

ESTIMATED LEAD TIME DOES NOT START UNTIL WE RECEIVE THIS
PRINT WITH YOUR APPROVAL SIGNATURE ON IT WITH NO CHANGES

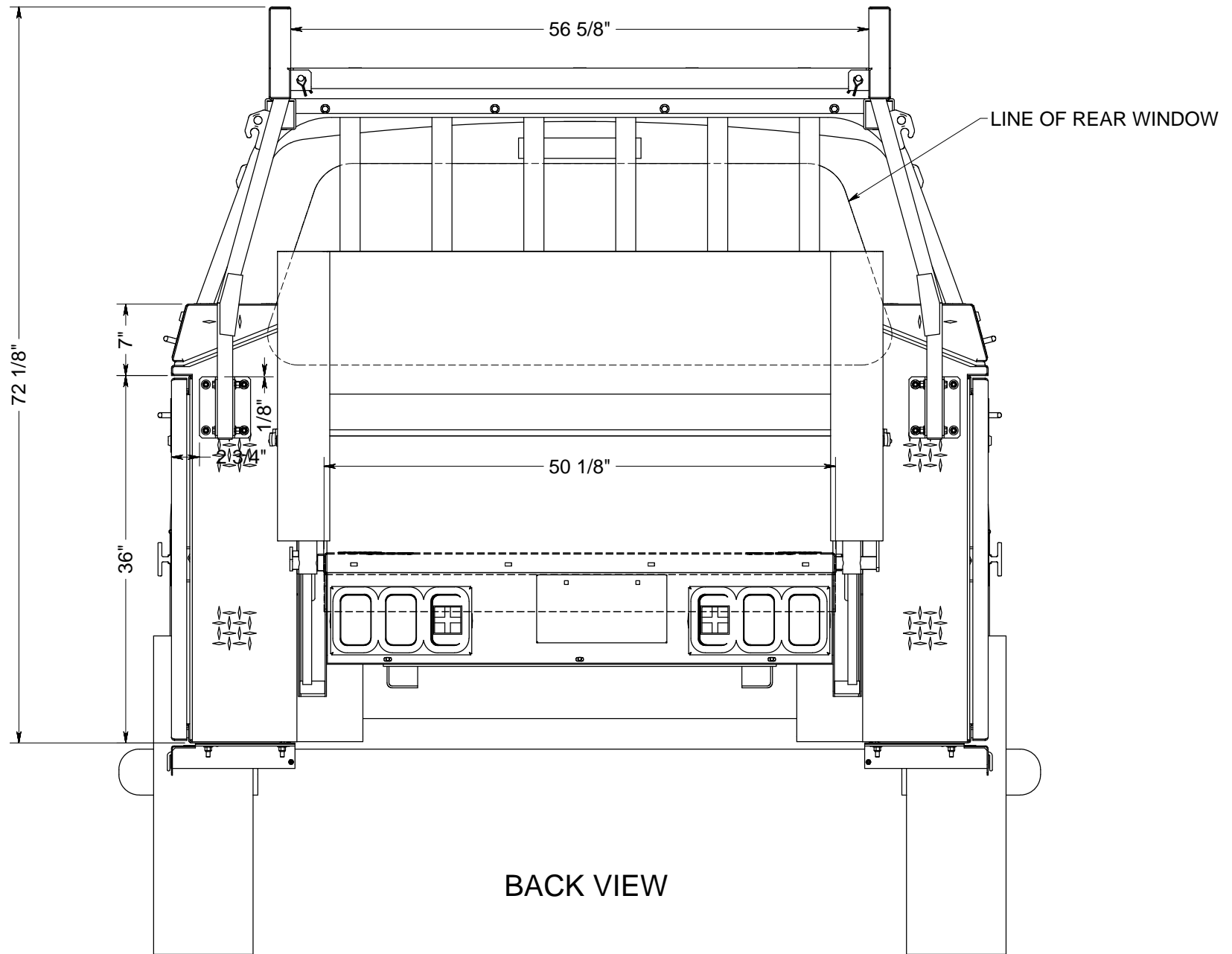

APPROVAL SIGNATURE _____

ESTIMATED LEAD TIME DOES NOT START UNTIL WE RECEIVE THIS
PRINT WITH YOUR APPROVAL SIGNATURE ON IT WITH NO CHANGES

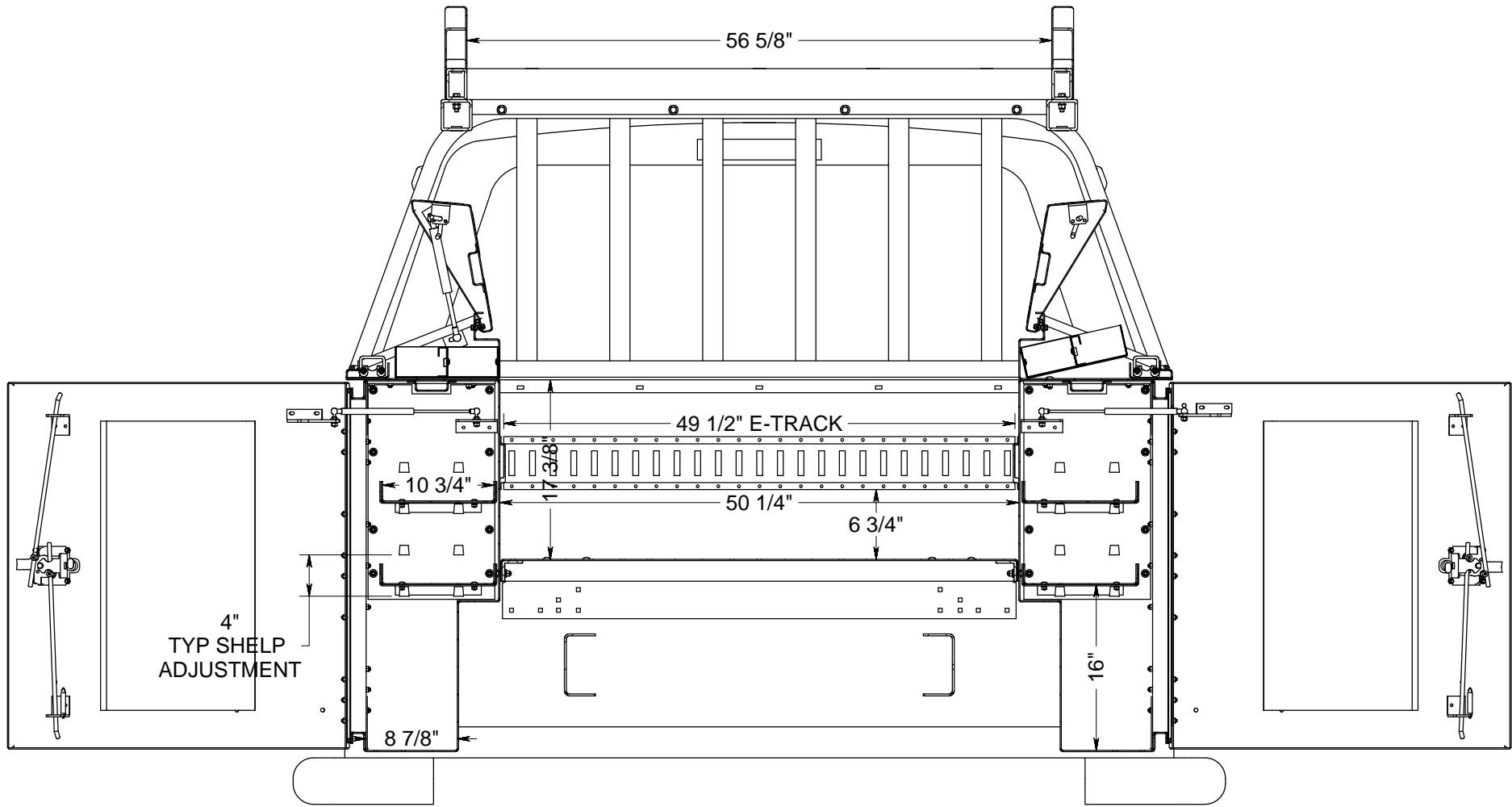

FRONT BOX SECTION A-A

APPROVAL SIGNATURE _____

ESTIMATED LEAD TIME DOES NOT START UNTIL WE RECEIVE THIS PRINT WITH YOUR APPROVAL SIGNATURE ON IT WITH NO CHANGES

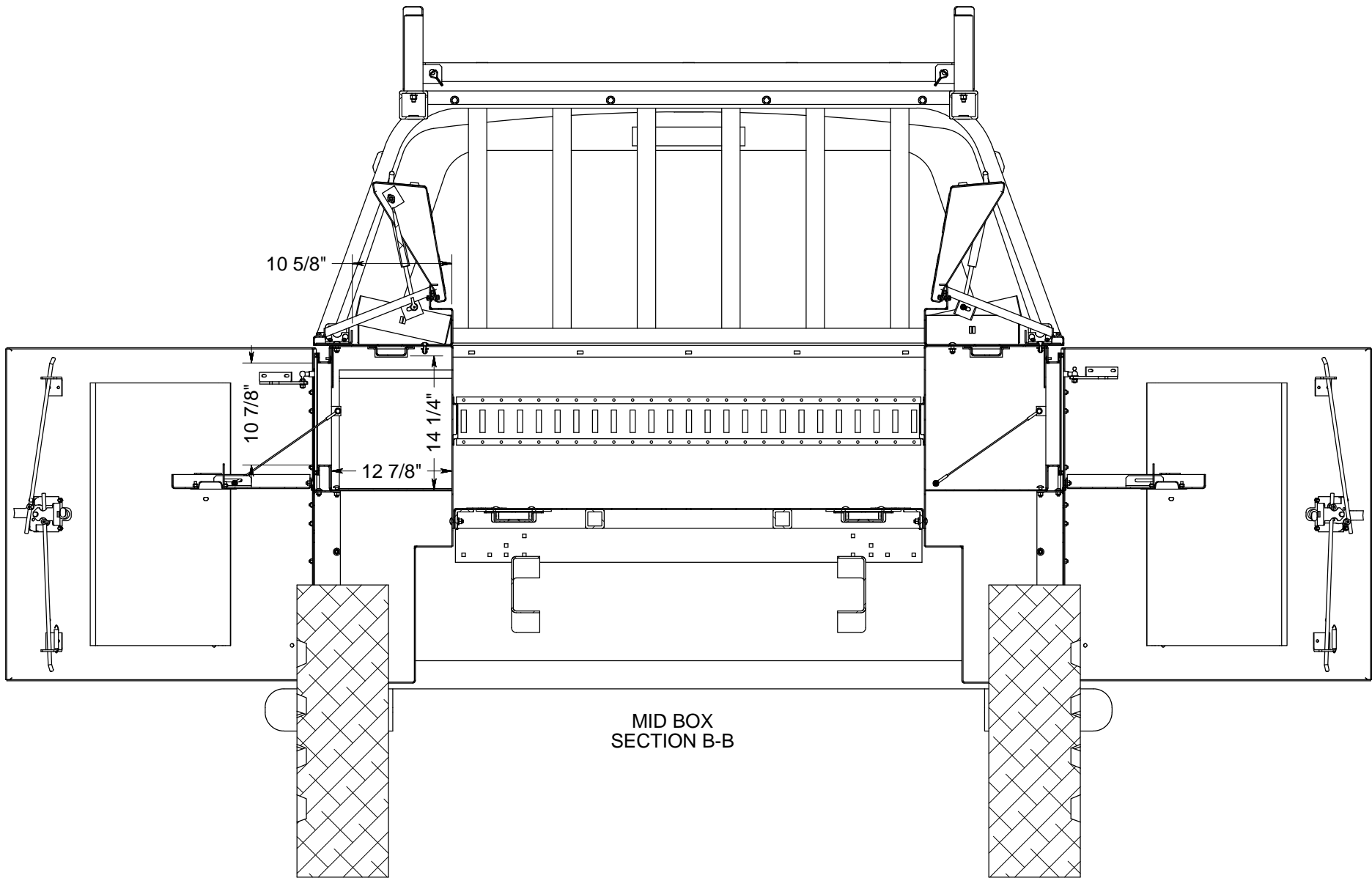

MID BOX
SECTION B-B

APPROVAL SIGNATURE _____

ESTIMATED LEAD TIME DOES NOT START UNTIL WE RECEIVE THIS
PRINT WITH YOUR APPROVAL SIGNATURE ON IT WITH NO CHANGES

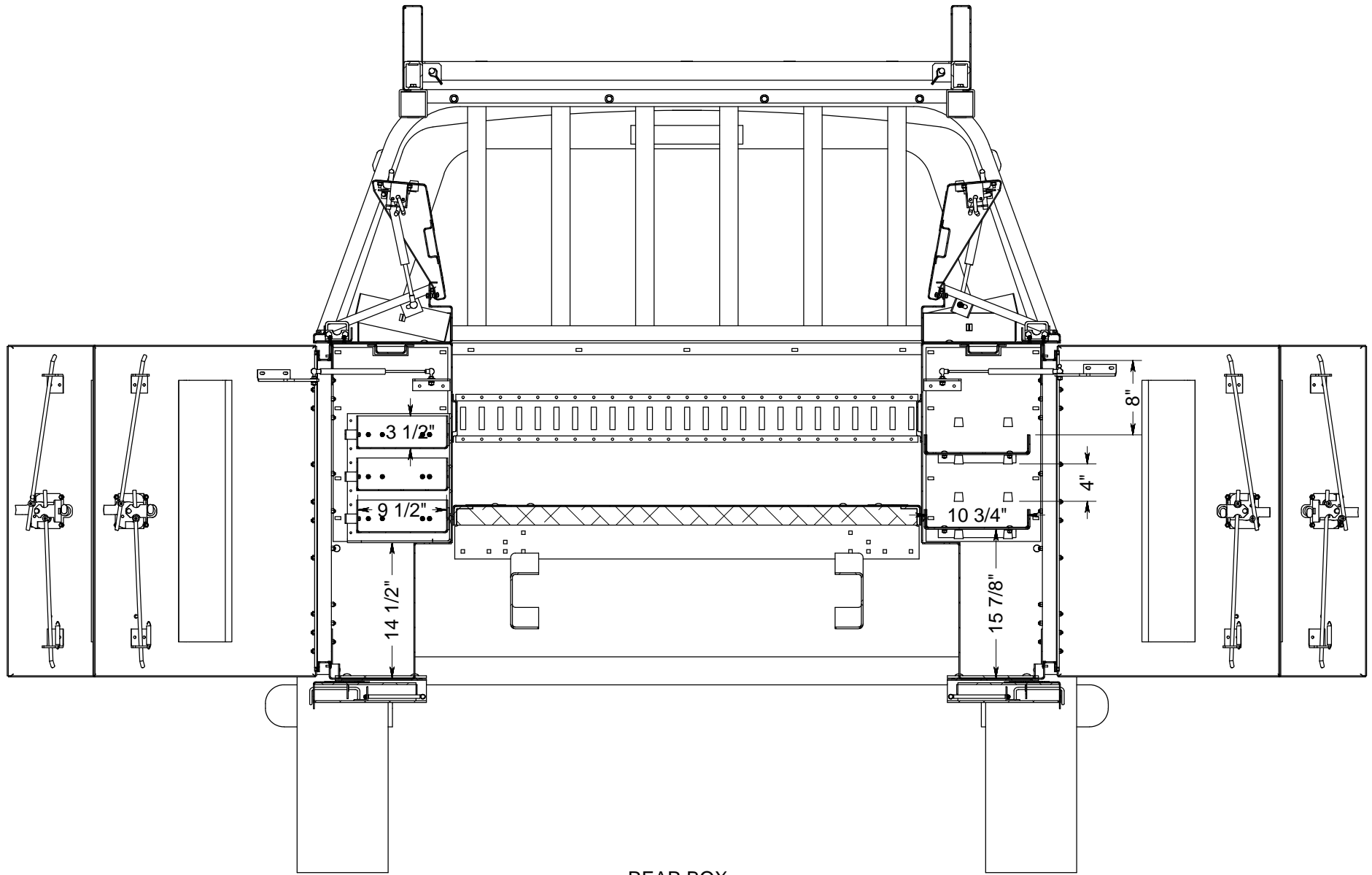

REAR BOX SECTION C-C

APPROVAL SIGNATURE _____

ESTIMATED LEAD TIME DOES NOT START UNTIL WE RECEIVE THIS PRINT WITH YOUR APPROVAL SIGNATURE ON IT WITH NO CHANGES